

INSTALLATION INSTRUCTIONS

Air Conditioner

Panasonic®

This air conditioner uses the refrigerant R410A.

Model No.

Indoor Units		Rated Capacity						
Type	Indoor Units Type	15	22	28	36	45	56	60
F3	Middle Static Pressure Duct	S-15MF3E5AN	S-22MF3E5AN	S-28MF3E5AN	S-36MF3E5AN	S-45MF3E5AN	S-56MF3E5AN	S-60MF3E5AN

Indoor Units		Rated Capacity					
Type	Indoor Units Type	73	90	106	112	140	160
F3	Middle Static Pressure Duct	S-73MF3E5AN	S-90MF3E5AN	S-106MF3E5AN	S-112MF3E5AN	S-140MF3E5AN	S-160MF3E5AN



ENGLISH

Read through the Installation Instructions before you proceed with the installation.
In particular, you will need to read under the "IMPORTANT!" section at the top of the page.

CONTENTS

	Page		Page
IMPORTANT	3	7. HOW TO INSTALL WIRELESS REMOTE CONTROLLER	39
Please Read Before Starting		NOTE	
		Refer to the Installation Instructions attached to the optional Wireless Remote Controller.	
1. GENERAL	7	8. PRECAUTIONS ON TEST RUN	39
1-1. Tools Required for Installation (not supplied)		9. CHECKLIST AFTER INSTALLATION WORK	40
1-2. Accessories Supplied with Unit		10. EXTERNAL STATIC PRESSURE SETTING	41
1-3. Type of Copper Tube and Insulation Material		10-1. How to Set on Indoor Unit Control PCB	
1-4. Additional Materials Required for Installation		10-2. Operating the High-spec Wired Remote Controller (CZ-RTC5B)	
		10-3. Operating the Timer Remote Controller (CZ-RTC4)	
2. SELECTING THE INSTALLATION SITE	9	10-4. Operating the Wired Remote Controller (CZ-RTC6 series)	
2-1. Indoor Unit		11. APPENDIX	61
3. HOW TO INSTALL THE INDOOR UNIT	10	■ Care and Cleaning	
3-1. Required Minimum Space for Installation and Maintenance Services		■ Troubleshooting	
3-2. Preparation Before Installation		■ Tips for Energy Saving	
3-3. Fix the Indoor Unit		Important Information Regarding The Refrigerant Used	65
3-4. Installing the Drain Pipe			
3-5. Checking the Drainage			
3-6. Connecting Duct to Air Intake Port Side			
4. ELECTRICAL WIRING	26		
4-1. General Precautions on Wiring			
4-2. Wire Length and Wire Diameter for Power Supply System			
4-3. Wiring System Diagrams			
5. HOW TO PROCESS TUBING	35		
5-1. Connecting the Refrigerant Tubing			
5-2. Connecting Tubing Between Indoor and Outdoor Units			
5-3. Insulating the Refrigerant Tubing			
5-4. Taping the Tubes			
5-5. Finishing the Installation			
6. HOW TO INSTALL THE TIMER REMOTE CONTROLLER OR HIGH-SPEC WIRED REMOTE CONTROLLER (OPTIONAL PART)	39		
NOTE			
Refer to the Installation Instructions attached to the optional Timer Remote Controller or optional High-spec Wired Remote Controller.			

IMPORTANT! Please Read Before Starting

This air conditioner must be installed by the sales dealer or installer.
This information is provided for use only by authorized persons.

For safe installation and trouble-free operation, you must:

- This Installation Instructions is for the indoor unit and read the Installation Instructions of the outdoor unit as well.
- Carefully read this instruction booklet before beginning.
- This air conditioner is required to have the remote controller which is adaptable to nanoe™ X function.
- Follow each installation or repair step exactly as shown.
- This air conditioner shall be installed in accordance with National Wiring Regulations.
- That compliance with national gas regulations shall be observed.
- The product meets the technical requirements of EN/IEC 61000-3-3.

- Pay close attention to all warning and caution notices given in this manual.



WARNING

This symbol refers to a hazard or unsafe practice which can result in severe personal injury or death.



CAUTION

This symbol refers to a hazard or unsafe practice which can result in personal injury or product or property damage.

If Necessary, Get Help

These instructions are all you need for most installation sites and maintenance conditions. If you require help for a special problem, contact our sales/service outlet or your certified dealer for additional instructions.

In Case of Improper Installation

The manufacturer shall in no way be responsible for improper installation or maintenance service, including failure to follow the instructions in this document.

SPECIAL PRECAUTIONS



WARNING When Wiring



ELECTRICAL SHOCK CAN CAUSE SEVERE PERSONAL INJURY OR DEATH. ONLY A QUALIFIED, EXPERIENCED ELECTRICIAN SHOULD ATTEMPT TO WIRE THIS SYSTEM.

- Do not supply power to the unit until all wiring and tubing are completed or reconnected and checked.
- Highly dangerous electrical voltages are used in this system. Carefully refer to the wiring diagram and these instructions when wiring. Improper connections and inadequate grounding can cause **accidental injury or death**.
- Connect all wiring tightly. Loose wiring may cause overheating at connection points and a possible fire hazard.
- Provide a power outlet to be used exclusively for each unit.
- Provide a power outlet exclusively for each unit, and full disconnection means having a contact separation by 3 mm in all poles must be incorporated in the fixed wiring in accordance with the wiring rules.
- To prevent possible hazards from insulation failure, the unit must be grounded. 
- This equipment is strongly recommended to be installed with Earth Leakage Circuit Breaker (ELCB) or Residual Current Device (RCD). Otherwise, it may cause electrical shock and fire in case of equipment breakdown or insulation breakdown.

When Transporting

- It may need two or more people to carry out the installation work.
- Be careful when picking up and moving the indoor and outdoor units. Get a partner to help, and bend your knees when lifting to reduce strain on your back. Sharp edges or thin aluminum fins on the air conditioner can cut your fingers.

When Installing...

- Select an installation location which is rigid and strong enough to support or hold the unit, and select a location for easy maintenance.
- Make sure to install protective guards on the suction and discharge side to prevent somebody from touching the fan motor, fan blades or heat exchanger.

...In a Room

Properly insulate any tubing run inside a room to prevent “sweating” that can cause dripping and water damage to walls and floors.



CAUTION Keep the fire alarm and the air outlet at least 1.5 m away from the unit.

...In Moist or Uneven Locations

Use a raised concrete pad or concrete blocks to provide a solid, level foundation for the outdoor unit. This prevents water damage and abnormal vibration.

...In an Area with High Winds

Securely anchor the outdoor unit down with bolts and a metal frame. Provide a suitable air baffle.

...In a Snowy Area (for Heat Pump-type Systems)

Install the outdoor unit on a raised platform that is higher than drifting snow. Provide snow vents.

...At Least 1.8 m (Horizontal Installation)

Installation height for indoor unit shall be at least 1.8 m in the case of horizontal installation.

However, choose the lowest among the following locations.

- Air inlet side of indoor unit
- Air outlet side of indoor unit
- Air inlet port in the room
- Air outlet port in the room

...In Laundry Rooms

Do not install in laundry rooms. Indoor unit is not drip proof.

When Connecting Refrigerant Tubing

Pay particular attention to refrigerant leakages.

WARNING

- When performing piping work, do not mix air except for specified refrigerant in refrigeration cycle. It causes capacity down, and risk of explosion and injury due to high tension inside the refrigerant cycle.
- If the refrigerant comes in contact with a flame, it produces toxic gases.
- Do not add or replace refrigerant other than specified type. It may cause product damage, burst and injury, etc.
- Ventilate the room immediately in the event of a refrigerant gas leakage during installation. Be careful not to allow contact of the refrigerant gas with a flame as this will cause the generation of toxic gases.
- Keep all tubing runs as short as possible.
- Apply refrigerant lubricant to the matching surfaces of the flare and union tubes before connecting them, then tighten the nut with a torque wrench for a leak-free connection.
- Check carefully for leaks before starting the test run.
- Do not leak refrigerant while piping work for an installation or re-installation, and while repairing refrigeration parts.
Handle liquid refrigerant carefully as it may cause frostbite.

When Servicing

- Be sure to turn off the power before servicing.
- Turn the power OFF at the main power box (mains), wait at least 5 minutes until it is discharged, then open the unit to check or repair electrical parts and wiring. 
- Keep your fingers and clothing away from any moving parts.
- Clean up the site after you finish, remembering to check that no metal scraps or bits of wiring have been left inside the unit.

WARNING

- This product must not be modified or disassembled under any circumstances. Modified or disassembled unit may cause fire, electric shock or injury.
- Do not clean inside the indoor and outdoor units by users. Engage authorized dealer or specialist for cleaning.
- In case of malfunction of this appliance, do not repair by yourself. Contact the sales dealer or service dealer for a repair and disposal.

CAUTION

- Ventilate any enclosed areas when installing or testing the refrigeration system. Leaked refrigerant gas, on contact with fire or heat, can produce dangerously toxic gases.
- Confirm after installation that no refrigerant gas is leaking. If the gas comes in contact with a burning stove, gas water heater, electric room heater or other heat source, it can cause the generation of toxic gases.

Others



WARNING

- Do not sit or step on the unit. You may fall down accidentally.



CAUTION

- Do not touch the air inlet or the sharp aluminum fins of the outdoor unit. You may get injured.
- Do not stick any object into the FAN CASE. You may be injured and the unit may be damaged.



NOTICE

The English text is the original instructions. Other languages are translations of the original instructions.











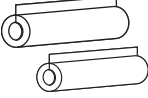

1. GENERAL

This booklet briefly outlines where and how to install the air conditioning system. Please read over the entire set of instructions for the indoor and outdoor units and make sure all accessory parts listed are with the system before beginning.

1-1. Tools Required for Installation (not supplied)

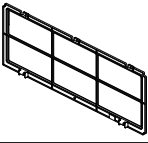
1. Flathead screwdriver
2. Phillips head screwdriver
3. Knife or wire stripper
4. Tape measure
5. Carpenter's level
6. Sabre saw or keyhole saw
7. Hacksaw
8. Core bits
9. Hammer
10. Drill
11. Tube cutter
12. Tube flaring tool
13. Torque wrench
14. Adjustable wrench
15. Reamer (for deburring)

1-2. Accessories Supplied with Unit

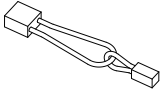
Part Name	Figure	Q'ty	Remarks
Washer		8	For suspending indoor unit from ceiling
Flare insulator		2	For gas and liquid tubes
Insulating tape		2	For gas and liquid tubes flare nuts
Drain insulator		1	For drain hose joint
Hose band		1	For securing drain hose
Packing		2	For drain hose joint (hard material)
Clamper		2	For drain hose joint
Drain hose		1	For main unit + PVC pipe joints
Clamper		2	For electrical wiring
Clamper		2	In the case of using the Solenoid Valve Controller (for connecting 3WAY VRF outdoor unit)
Filter		*	When not connecting the air intake, be sure to install the filter.
Screw		*	
Operating Instructions		1	
Installation Instructions		1	
Short-circuit connection		1	For vertical installation (Located on the back of the electrical component box lid.)

* 1 Q'ty : Type 15, 22, 28, 36, 45, 56
 2 Q'ty : Type 60, 73, 90
 2 Q'ty : Type 106, 112, 140, 160

- Use M10 for suspension bolts.
- Field supply for suspension bolts and nuts.

1-3. Type of Copper Tube and Insulation Material

If you wish to purchase these materials separately from a local source, you will need:

1. Deoxidized annealed copper tube for refrigerant tubing.
2. Foamed polyethylene insulation for copper tubes as required to precise length of tubing. Wall thickness of the insulation should be not less than 8 mm.
3. Use insulated copper wire for field wiring. Wire size varies with the total length of wiring. See Section "4. ELECTRICAL WIRING" for details.



CAUTION

Check local electrical codes and regulations before obtaining wire. Also, check any specified instructions or limitations.

1-4. Additional Materials Required for Installation

1. Refrigeration (armored) tape
2. Insulated staples or clamps for connecting wire (See your local codes.)
3. Putty
4. Refrigeration tubing lubricant
5. Clamps or saddles to secure refrigerant tubing
6. Scale for weighing

2. SELECTING THE INSTALLATION SITE

2-1. Indoor Unit

AVOID:

- areas where leakage of flammable gas may be expected.
- places where large amounts of oil mist exist.
- direct sunlight.
- locations near heat sources which may affect the performance of the unit.
- locations where external air may enter the room directly. This may cause “condensation” on the air discharge ports, causing them to spray or drip water.
- locations where the remote controller will be splashed with water or affected by dampness or humidity.
- installing the remote controller behind curtains or furniture.
- locations where high-frequency emissions are generated.

DO:

- select an appropriate position from which every corner of the room can be uniformly cooled.
- select a location where the ceiling is strong enough to support the weight of the unit.
- make sure to install protective guards on the suction and discharge side to prevent somebody from touching the fan motor, fan blades or heat exchanger.
- select a location where tubing and drain pipe have the shortest run to the outdoor unit.
- allow room for operation and maintenance as well as unrestricted airflow around the unit.
- the limitation of the tubing length between the indoor and the outdoor units should be referred to the Installation Instructions of the outdoor unit.
- allow room for mounting the remote controller about 1 m off the floor, in an area that is not in direct sunlight or in the flow of cool air from the indoor unit.

< Horizontal installation >

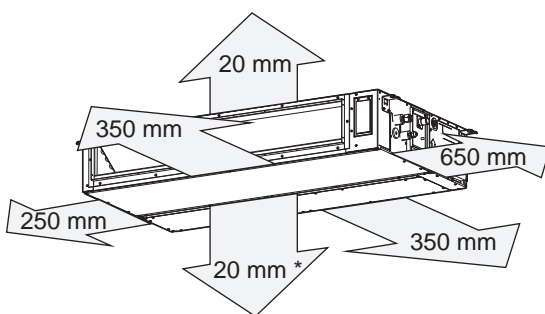

- * It is necessary to make space for the cleaning as well as the maintenance of the drain pan and the heat exchanger. Do not put any obstacle not to cause obstructing maintenance or cleaning works.
If the place where the ceiling material cannot be removed, make an opening section below the bottom surface of the indoor unit in order to take it out.
If it is impossible to provide an opening, make space more than 300 mm between the indoor unit's bottom surface and the ceiling material.

< Vertical installation >

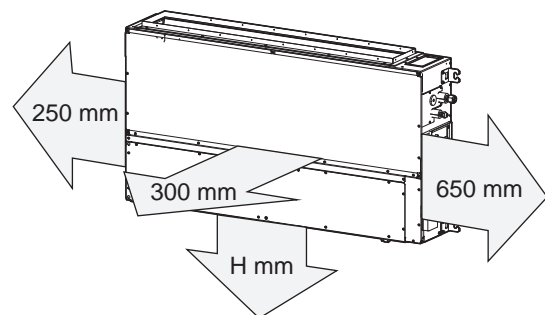

- H
- Lower side air intake with duct : 300 mm
 - Lower side air intake without duct : 200 mm
 - Front side air intake : 150 mm

3. HOW TO INSTALL THE INDOOR UNIT

3-1. Required Minimum Space for Installation and Maintenance Services

- This air conditioner is usually installed above the ceiling or behind the wall so that the indoor unit and ducts are not visible. Only the air intake and air outlet ports are visible from below.
- The minimum space for installation and maintenance services is shown in the figure.

< Horizontal installation >

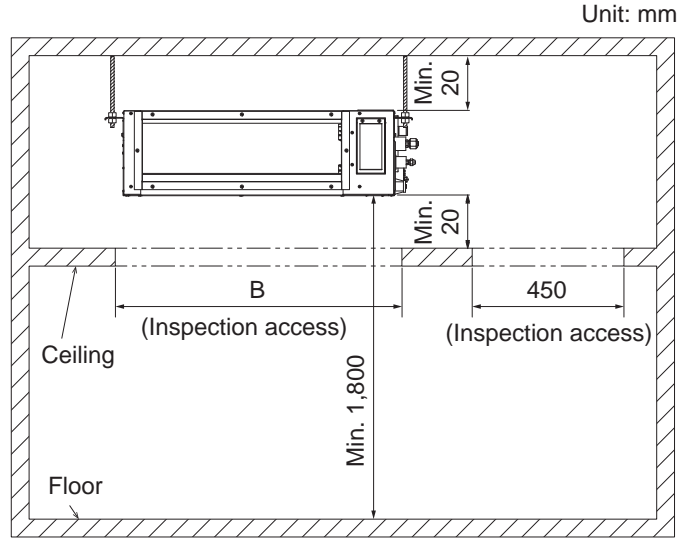
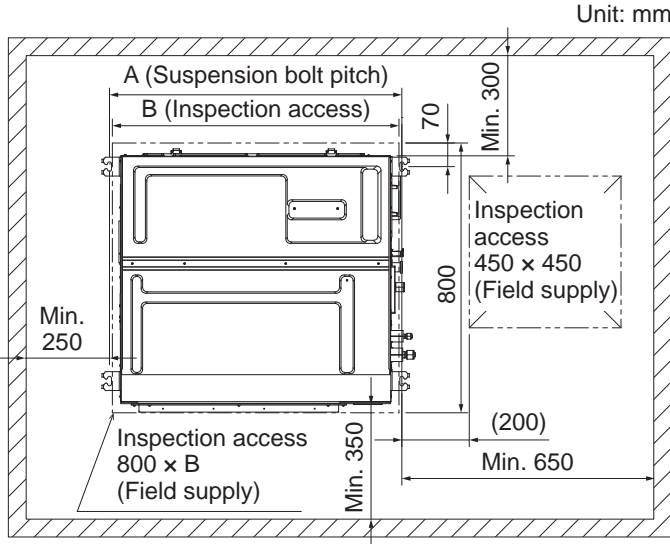

Minimum space for installation and maintenance services

Unit: mm

Type	15, 22, 28, 36, 45, 56	60, 73, 90	106, 112, 140, 160
A (Length)	867	1,067	1,467
B (Length)	850	1,050	1,450

It is necessary to make space for the cleaning and maintenance of the drain pan, the heat exchanger and filter fixed inlet.

Do not put any obstacle not to cause obstructing maintenance or cleaning works.

If the place where the ceiling material cannot be removed, make an inspection access (800 x B) below the bottom surface of the indoor unit in order to take it out.

If no space to provide inspection access (800 x B), there are two alternative cases (① or ② as below). However, when choosing those cases, there is not enough space available to offer heat exchanger maintenance service.

① Make space more than 300 mm between the indoor unit's bottom surface and the ceiling material.

② Install inspection access (450 x 450) both edge of indoor unit and make space more than 100 mm between the indoor unit's bottom surface and the ceiling material.

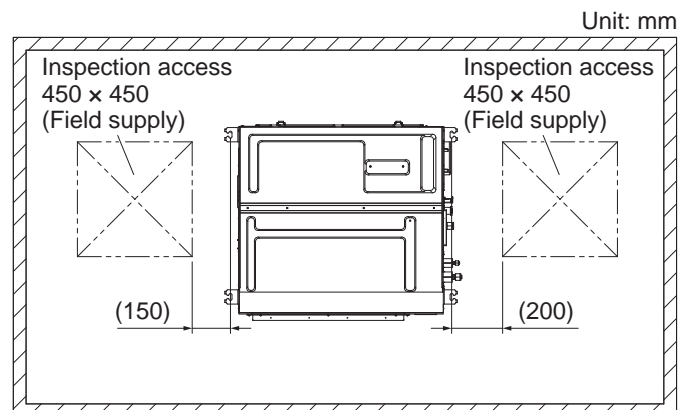
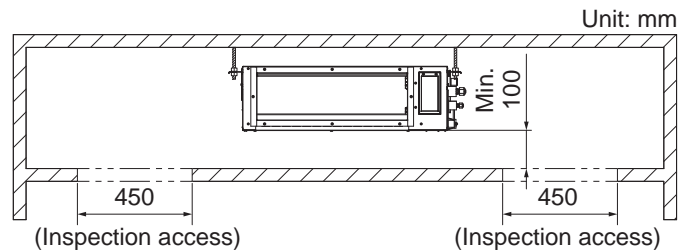
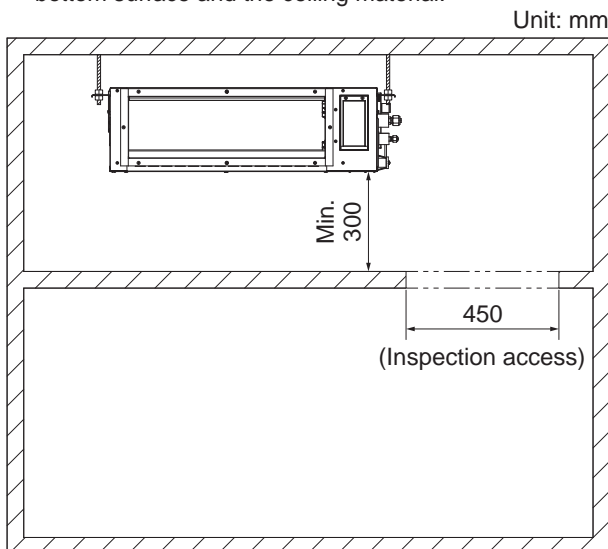

< Vertical installation >

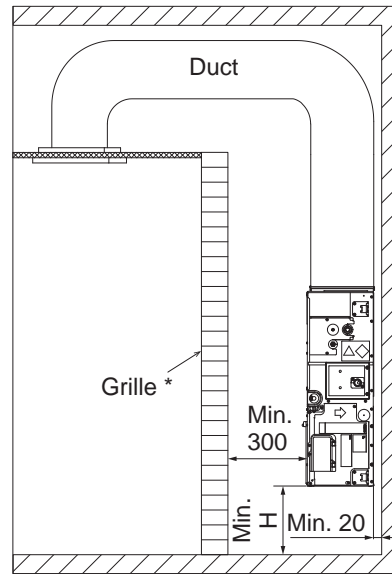
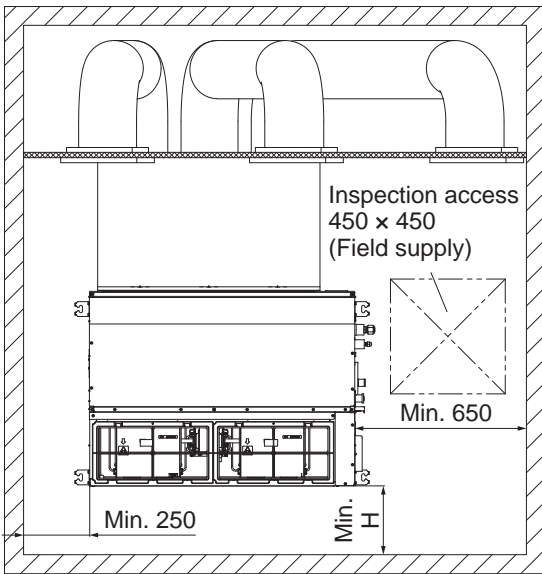

Unit: mm

H

- Lower side air intake with duct : 300 mm
- Lower side air intake without duct : 200 mm
- Front side air intake : 150 mm

* Make it possible to open / close for maintenance services for the drain pan, the heat exchanger and filter fixed inlet.

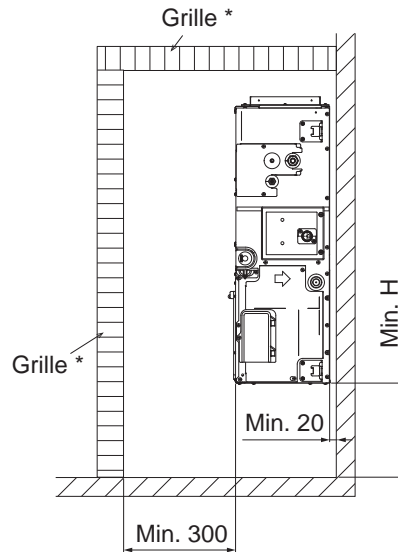
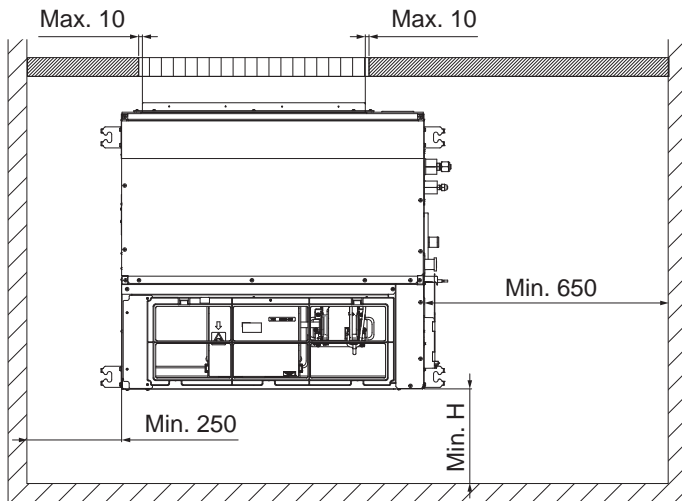

Unit: mm

H

- Lower side air intake with duct : 300 mm
- Lower side air intake without duct : 200 mm
- Front side air intake : 150 mm

* Make it possible to open / close for maintenance services.

- It is recommended that the space be provided (450 x 450 mm) for checking and servicing the electrical system.

Detailed dimensions of indoor unit

Type	A	B	C	D	E	F
	mm	mm	mm	mm	mm	Q'ty
15, 22, 28, 36, 45, 56	867	800	450 (Pitch 150 × 3)	71	592	12
60, 73, 90	1,067	1,000	750 (Pitch 150 × 5)	21	792	16
106, 112, 140, 160	1,467	1,400	1,050 (Pitch 150 × 7)	71	1,192	20

- a) Refrigerant tubing joint (liquid tube)
- b) Refrigerant tubing joint (gas tube)
- c) Upper drain port VP20 (ø26 mm)
200 mm flexible hose supplied
- d) Bottom drain port VP20 (ø26 mm)
- e) Suspension lug (4 – 12 × 30 mm)
- f) Power supply outlet
- g) Fresh air intake port (ø100 mm)
- h) Flange for flexible air outlet duct
- i) Electrical component box

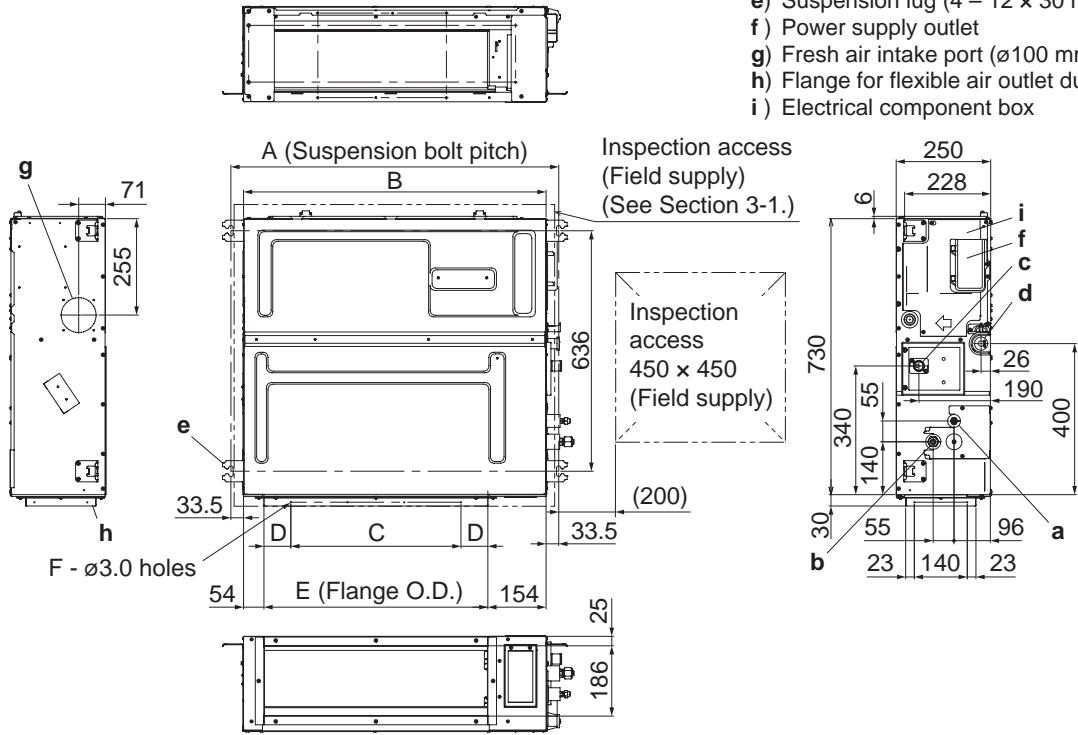

Unit: mm

3-2. Preparation Before Installation

3-2-1. Main Types of Installation

Case A (Standard installation)

Horizontal installation in the ceiling, rear side air intake

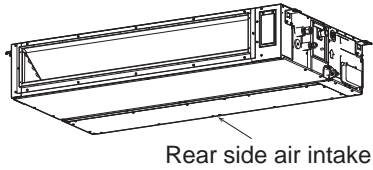

Case B

Horizontal installation in the ceiling, lower side air intake

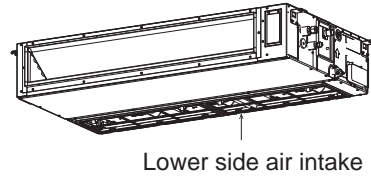

Case C

Vertical installation on the sidewall, lower side air intake

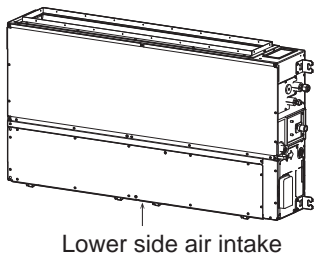

Case D

Vertical installation on the sidewall, front side air intake

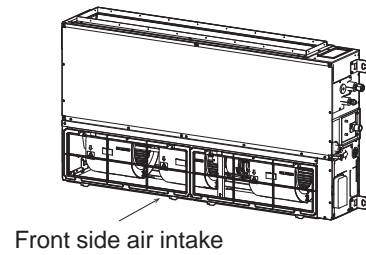

* While in heating mode, the temperatures may increase higher than the set temperature.

* While in heating mode, the temperatures may increase higher than the set temperature.

3-2-2. Install the Filter

When not connecting the air intake duct, be sure to install the filters (Accessories). Case A and Case C are shown below.

Type 15, 22, 28, 36, 45, 56

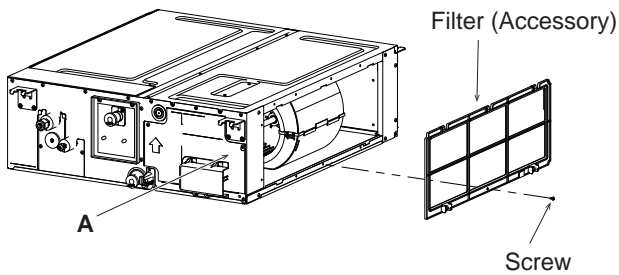

Type 60, 73, 90, 106, 112, 140, 160

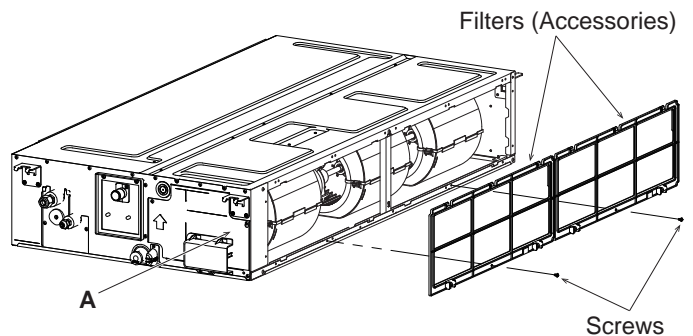

View A

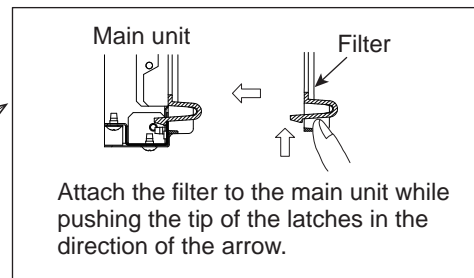
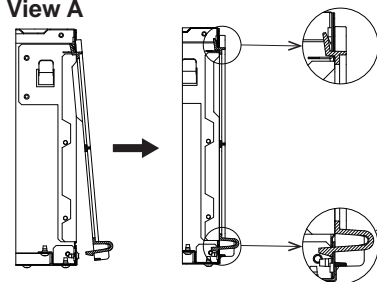

Attach the filters (accessories) in the manner shown in the figure. Securely fix the filters with the screws.

Case B and Case D are shown below.

For Case B and Case D, replace the cover plates in the procedure shown in the figure.

Type 15, 22, 28, 36, 45, 56

1. Remove the cover plates (2 pcs).

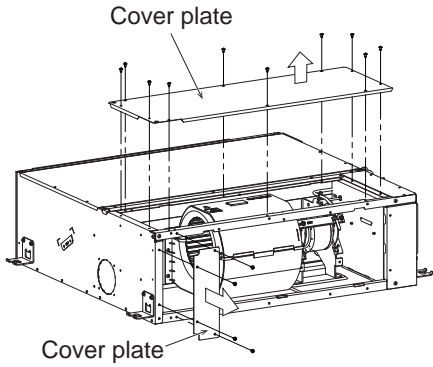

2. Attach the cover plates removed in Step 1 and filter (accessory) in the direction shown in the figure below.

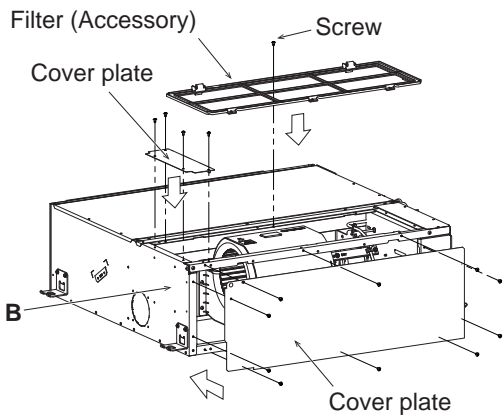

Type 60, 73, 90, 106, 112, 140, 160

1. Remove the cover plate and the support plate (Type 106, 112, 140, 160 only).

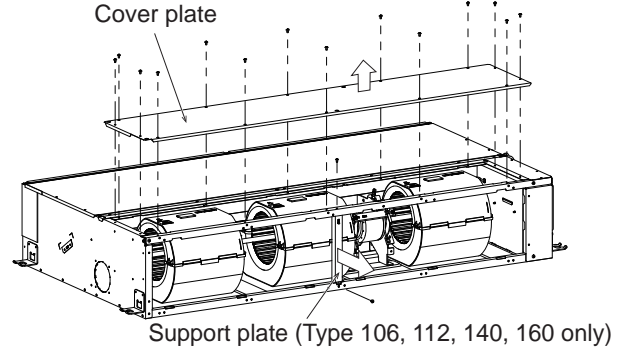

2. Attach the cover plate and the support plate removed in Step 1 and filters (accessories) in the direction shown in the figure below.

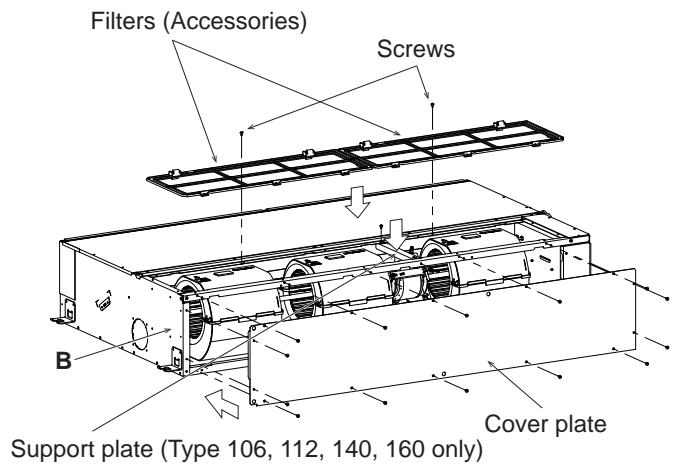

3. Attach the filters (accessories) in the manner shown in the figure. Securely fix the filters with the screws.

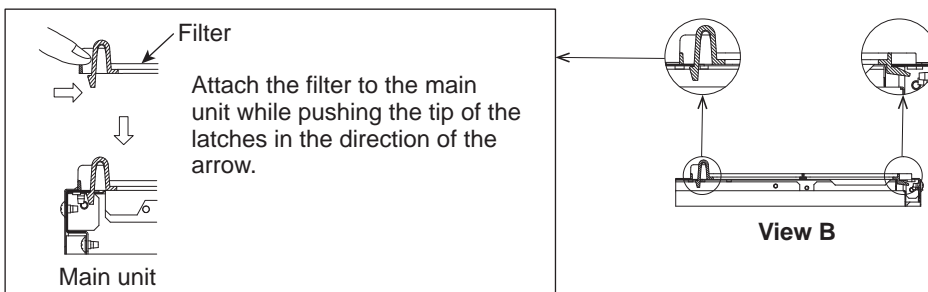

3-3. Fix the Indoor Unit

3-3-1. Horizontal Installation

Depending on the ceiling type:

- a) Insert suspension bolts.
or
- b) Use existing ceiling supports or construct a suitable support.

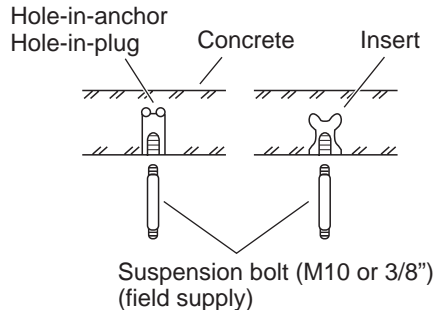

a)

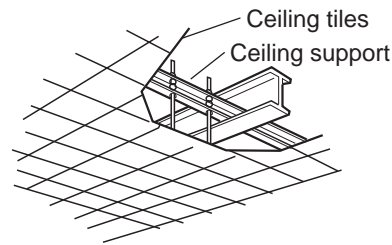

b)



WARNING

It is important that you use extreme care in supporting the indoor unit inside the ceiling. Ensure that the ceiling is strong enough to support the weight of the unit. Before hanging the unit, test the strength of each attached suspension bolt.

- (1) When placing the unit inside the ceiling, determine the pitch of the suspension bolts referring to the dimensional data as shown in the tables and diagrams under Section 3-1. Tubing must be laid and connected inside the ceiling when suspending the unit. If the ceiling is already constructed, lay the tubing into position for connection to the unit before placing the unit inside the ceiling.
- (2) Screw in the suspension bolts allowing them to protrude from the ceiling. (Cut the ceiling material, if necessary.)
- (3) Thread the 3 hexagonal nuts and 2 washers (field supply) onto each of the 4 suspension bolts. Use 1 nut and 1 washer for the upper part, and 2 nuts and 1 washer for the lower part, so that the unit will not fall off the suspension lugs.

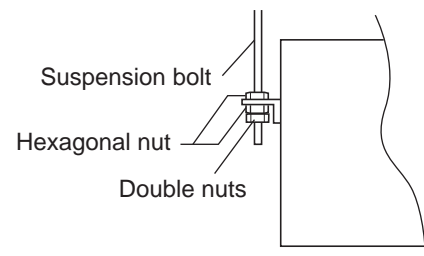
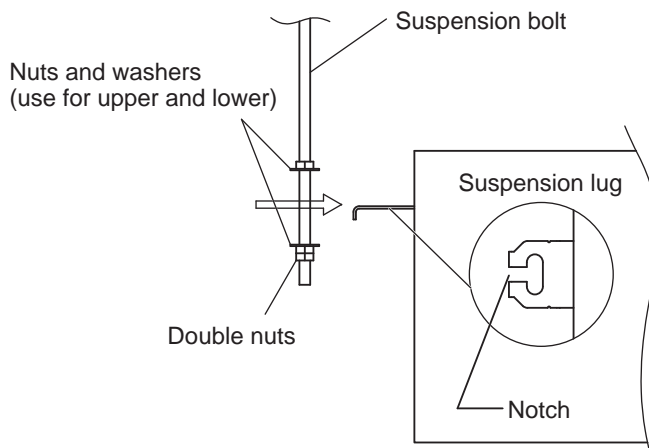

- This shows an example of installation.

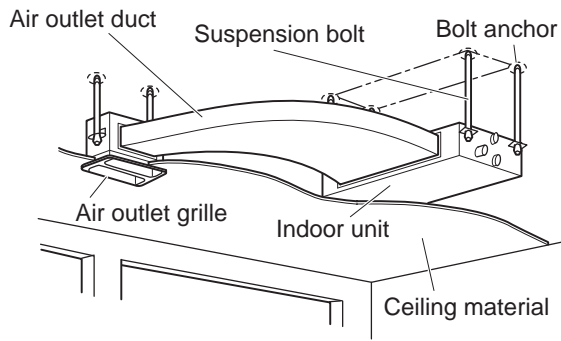

- Check to make sure the unit is installed in a horizontal position by using a level. Water leakage may occur if the unit is not installed horizontally.

3-3-2. Vertical Installation

- To prevent overturning, fasten the unit to the wall securely.
- Check to make sure the wall and the bolts can endure 5 times of weight of the unit. Ensure to fix the unit.
- In order to suppress vibrations, provide the spacer between the unit and the wall.
- Fasten the hanging brackets and bolts using by the hexagon nuts and washers.
- Check to make sure the unit is installed in a horizontal position by using a level. Water leakage may occur if the unit is not installed horizontally.

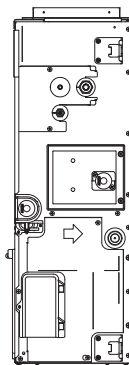
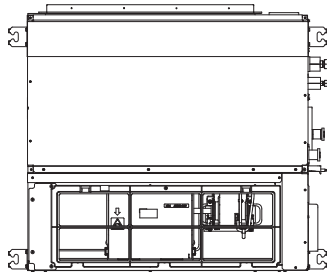

3-4. Installing the Drain Pipe

- (1) Prepare standard hard PVC pipe (O.D. 26 mm) for the drain and use the supplied hose band to prevent water leaks.
 The PVC pipe must be purchased separately.
 The transparent drain part on the unit allows you to check drainage.

⚠ CAUTION

- Do not use adhesive tape at the drain connection port on the indoor unit.
- Insert the drain pipe until it contacts the socket, and then secure it tightly with the hose band.
- Do not use the supplied drain hose bent at a 90° angle. (The maximum permissible bend is 45°.)
- Tighten the hose clamps so their locking nuts face upward.

- (2) Installing the drain hose

- First insert the drain hose (supplied) to the hose band (supplied) and then install the drain hose to the unit drain port.
- Insert until the drain hose bumps to the end.
- Hose band screw torque is 30 - 35 N · cm.
- Connect both the drain hose and PVC pipe (VP20 or similar material, not supplied). Insert until the PVC pipe bumps to the end and adhere with PVC adhesive.

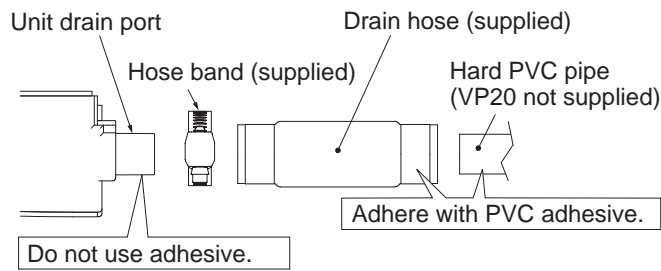

- (3) After connecting the drain pipe securely, wrap the supplied packing and drain pipe insulator around the pipe, then secure it with the clampers.

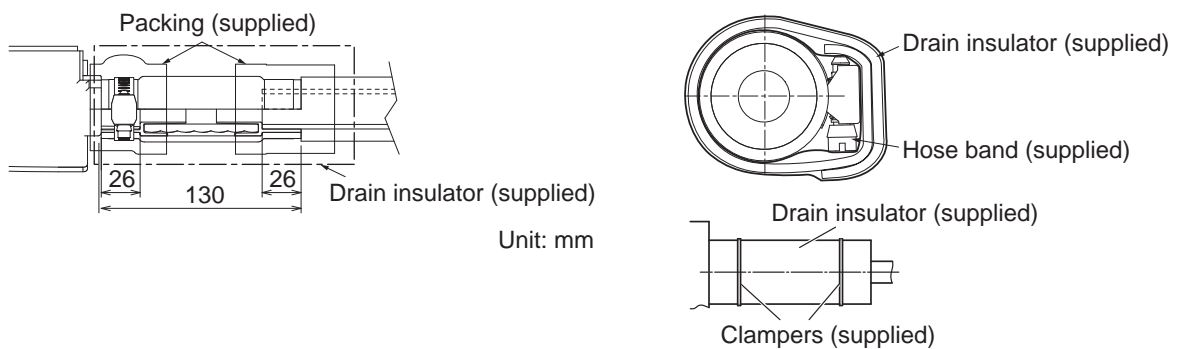

3-4-1. Horizontal Installation

NOTE

Make sure the drain pipe has a downward gradient (1/100 or more) and that there are no water traps.

CAUTION

- Do not install an air bleeder as this may cause water to spray from the drain pipe outlet.

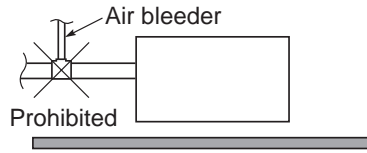

- If it is necessary to increase the height of the drain pipe, the section directly after the connection port can be raised a maximum of 500 mm. Do not raise it any higher than 500 mm, as this could result in water leaks.

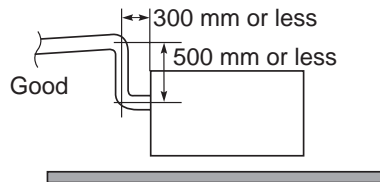

- Do not install the pipe with an upward gradient from the connection port. This will cause the drain water to flow backward and leak when the unit is not operating.

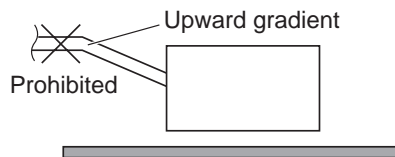

- Do not apply force to the piping on the unit side when connecting the drain pipe. The pipe should not be allowed to hang unsupported from its connection to the unit. Fasten the pipe to a wall, frame, or other support as close to the unit as possible.

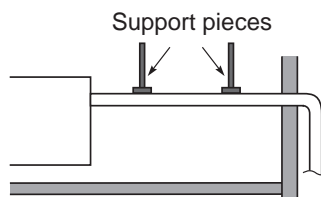

3-4-2. Vertical Installation

- Replace the drain cap

Remove the drain cap from the bottom drain port and reinstall it to the upper drain port. The drain cap can be inserted easily by using a screwdriver or similar tool to push the drain cap into the drain port on the main unit. Push the drain cap into the main unit's drain port until it reaches the end-stop.

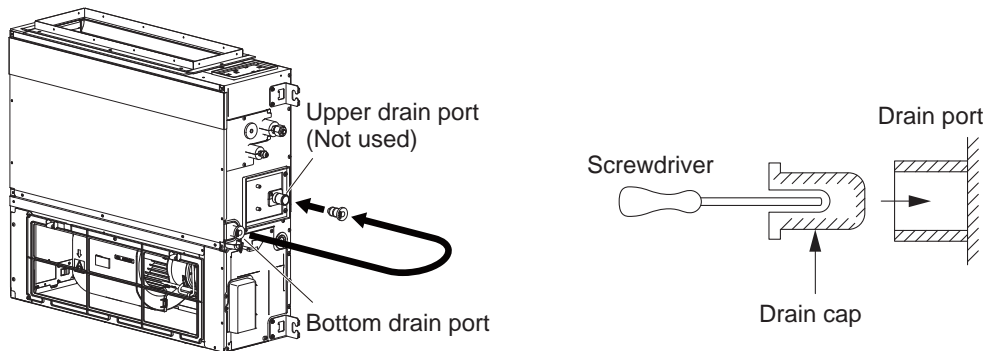

- Replace the connectors

When installing the unit vertically, disconnect the connectors of the drain pump (3-pin) and the float switch (2-pin) from the PCB.

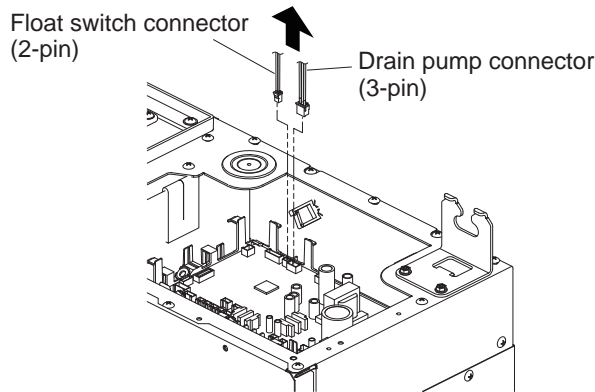

Insert the supplied short-circuit connection to the place where the connectors were removed.

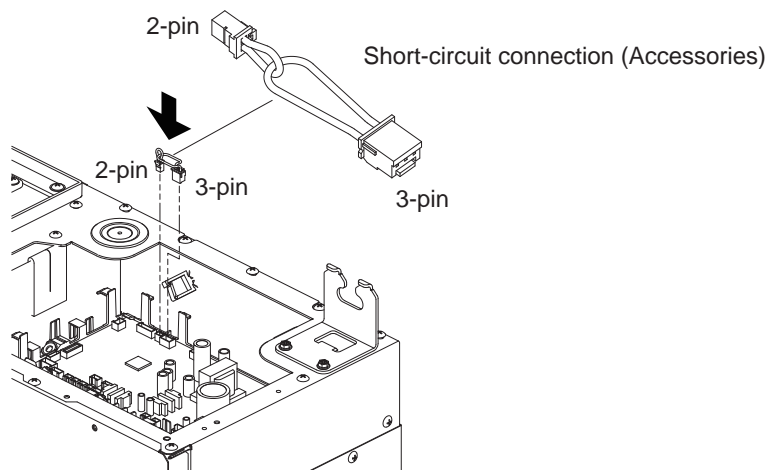



- * Pay attention to the type of connector.
- After switching on the power, invalidate the drain pump and change the heating intake temperature by setting the remote controller. (For details, see next page.)







How to make drain pump ineffective and changing heating intake temperature

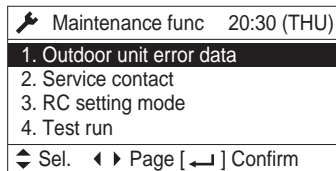



Operating the High-spec Wired Remote Controller (CZ-RTC5B)





After completing the address setting under Section “TEST RUN” of the outdoor unit installation instructions, carry out the following procedure.





1. Keep pressing the ,  and  buttons simultaneously for 4 or more seconds.
The “Maintenance func” screen appears on the LCD display.











2. Press the  or  button to see each menu.
If you wish to see the next screen instantly, press the  or  button.
Select “8. Detailed settings” on the LCD display and press the  button.
The “Detailed settings” screen appears on the LCD display.
3. Select the “Unit no.” by pressing the  or  button for changes.

4. Select the “Code no.” by pressing the  or  button.
Change the “Code no.” to “3F” by pressing the  or  button (or keeping it pressed).

5. Select the “Set data” by pressing the  or  button.
 (“0007” or “0000” set at shipment)
Change the Setting Data “0001” by pressing the  or  button.
Then press the  button.

6. Select the “Code no.” by pressing the  or  button.
Change the “Code no.” to “06” by pressing the  or  button (or keeping it pressed).



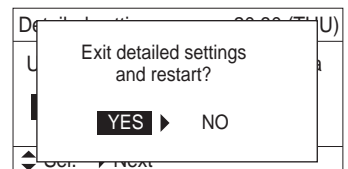
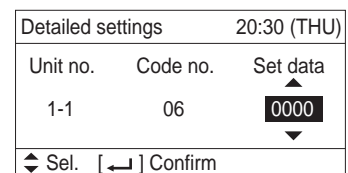
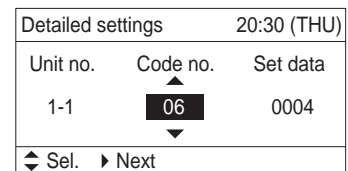
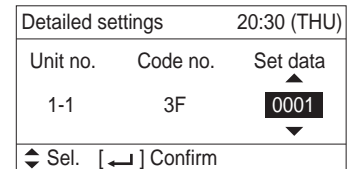
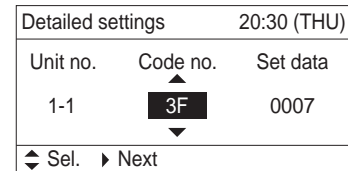
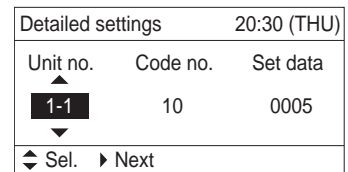
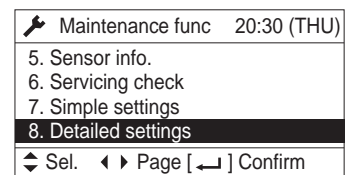
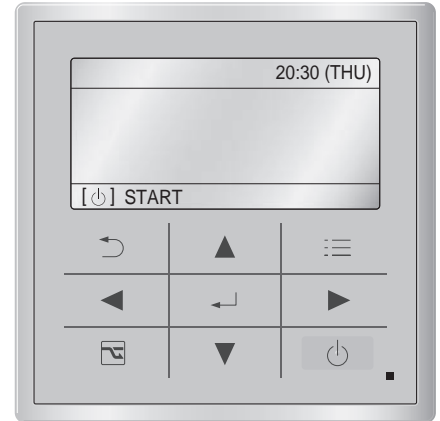

7. Select the “Set data” by pressing the  or  button.
 (“0004” set at shipment)
Change the Setting Data “0000” by pressing the  or  button.
Then press the  button.

8. Select the “Unit no.” by pressing the  or  button and press the  button.
The “Exit detailed settings and restart?” (Detailed setting-end) screen appears on the LCD display.
Select “YES” and press the  button.









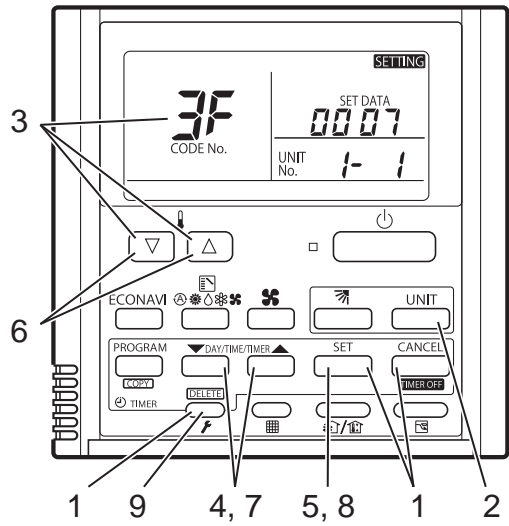



Operating the Timer Remote Controller (CZ-RTC4)

Setting Item Code “3F” and “06”

1. Press and hold down the ,  and  buttons simultaneously for 4 or more seconds.
(**SETTING**, the unit no., item code and detailed data will blink on the LCD display.)
2. The indoor unit numbers in the group control will be sequentially displayed whenever the Unit Select button is pressed .
Only the fan motor for the selected indoor unit will operate during this time.



3. Specify the “3F” item code by pressing the  /  buttons for the temperature setting buttons and confirm the values.
(“0007” or “0000” set at shipment)
4. Press the  /  buttons for the time to amend the values for the set data.
Select “0001”.
5. Press the  button.
The display will stop blinking and remain illuminated.
6. Specify the “06” item code by pressing the  /  buttons for the temperature setting buttons and confirm the values.
(“0004” set at shipment)
7. Press the  /  buttons for the time to amend the values for the set data.
Select “0000”.
8. Press the  button.
The display will stop blinking and remain illuminated.
9. Press the  button to return to normal remote controller display.



*Failure to make this setting may cause malfunction of the drain pump.

Operating the Wired Remote Controller (CZ-RTC6 series)

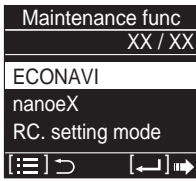

1. Keep pressing the ,  and  buttons simultaneously for 4 or more seconds.





The “Maintenance func” screen appears on the LCD display.













2. Press the  or  button to see each menu. Select “Detailed settings” on the LCD display and press the  button.





The “Detailed settings” screen appears on the LCD display.





3. Select the “Unit no.” by pressing the  or  button. After selecting “Unit no.”, press the  button and proceed to Step 4.

4. Select the “Code no.” by pressing the  or  button. Change the value by pressing the  or  button to [00003F]. After selecting “Code no.”, press the  button and proceed to Step 5.

5. Select the “Set data” by pressing the  or  button. (“0007” or “0000” set at shipment) Change the Setting Data “0001” by pressing the  or  button. After selecting “Set data”, press the  button and proceed to Step 6.

6. Select the “Code no.” by pressing the  or  button. Change the value by pressing the  or  button to [000006]. After selecting “Code no.”, press the  button and proceed to Step 7.

7. Select the “Set data” by pressing the  or  button. (“0004” set at shipment) Change the Setting Data “0000” by pressing the  or  button. After selecting “Set data”, press the  button. (If setting continuously, follow the procedures from Step 3.)

8. If the  button is pressed under the display Step 3, the following display (Detailed setting-end screen) appears. Then select “YES” by pressing the  or  button and press the  button.

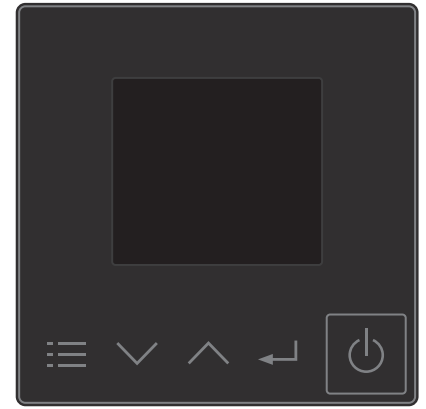

Black

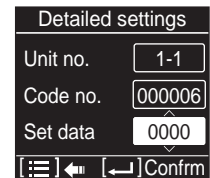
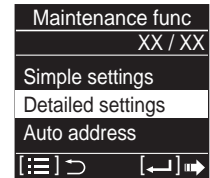

NOTE

The wired remote controller illustrated right can also be available following the same procedures as above.



White

NOTE

Make sure the drain pipe has a downward gradient (1/100 or more) and that there are no water traps.

 **CAUTION**

- Do not install an air bleeder as this may cause water to spray from the drain pipe outlet.

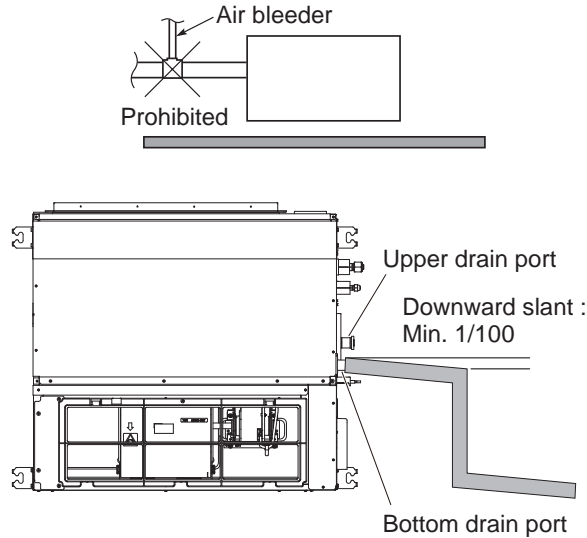

(1) Drain hose connection

- The drain hose is connected below the refrigerant tubing.

 **CAUTION**

- Wrap the drain insulator (supplied) between the connection of the drain hose and tubing not to expose the copper tubing. Also, wrap the hose band together. Wrap the hose band with the drain insulator, where the screw is located facing upward. Then, tighten the insulator with a vinyl tape not to cause the detachment. If the tubing parts remain exposed, condensation may occur.
- Be sure to use the supplied drain hose.
- If other commercially available hose bands are used, the drain hose may become pinched or wrinkled and there is danger of water leakage. Therefore be sure to use the supplied hose bands.
- Connect the drain pipe so that it slopes downward from the unit to the outside.
- Never allow water traps to occur in the course of the piping.
- Insulate any piping inside the room to prevent dripping.
- After the drain piping, pour an appropriate amount of water into the drain pan through the opening on the side of the air discharge port. Check the water draining smoothly.

3-5. Checking the Drainage

3-5-1. Horizontal Installation Only

After wiring and drain piping are completed, use the following procedure to check that the water will drain smoothly. For this, prepare a bucket and wiping cloth to catch and wipe up spilled water.

- (1) Connect power to the power terminal board (L, N terminals) inside the electrical component box.
- (2) Remove the tube cover and slowly pour about 1,200 cc of water through the opening into the drain pan to check drainage.
- (3) Short the check pin (CHK) (6P : 1-4) on the indoor unit control PCB and operate the drain pump. Check the water flow through the transparent upper drain port and see if there is any leakage.
 - * If the check pin (CHK) (6P : 1-4) is shorted, the fan starts rotating at high speed and could cause injury.
- (4) When the drainage check is complete, open the check pin (CHK) (6P : 1-4) and remount the insulator and the cap onto the drain inspection port.

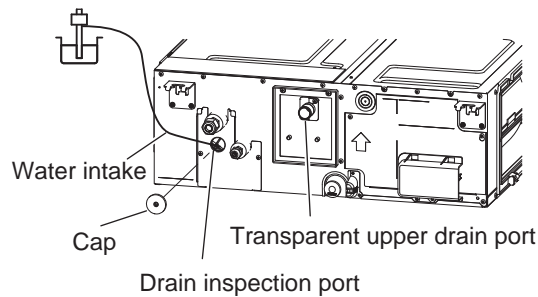

3-6. Connecting Duct to Air Intake Port Side

- (1) Install the duct (field supply).
See the figure for the dimension of the installation hole.
Use M4 self-tapping screws for installation.

Type 15, 22, 28, 36, 45, 56

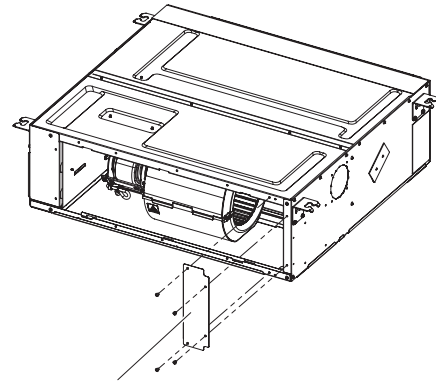
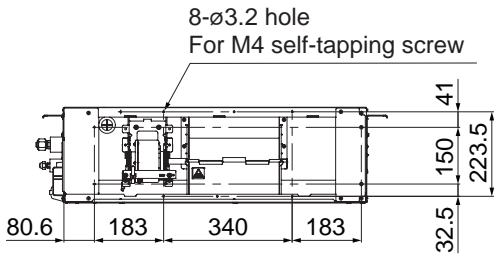

Remove the cover plate
(Type 15, 22, 28, 36, 45, 56 only)

Type 60, 73, 90

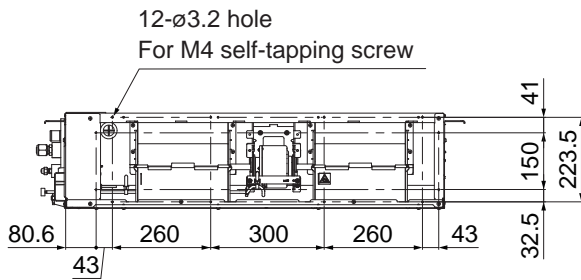

Type 106, 112, 140, 160

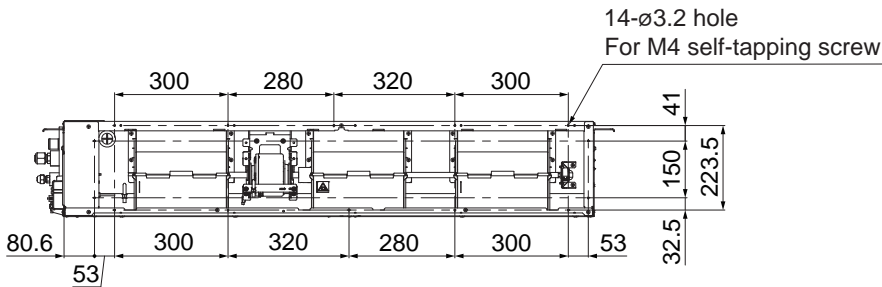

Unit: mm

NOTE

To get clean air and to extend the service life of the air conditioner, an air filter must be installed in the air intake. Using duct to air intake, install the filter (field supply) to air intake duct instead of filter (supplied).

For installation and cleaning the air filter, consult your dealer or service center.

4. ELECTRICAL WIRING

4-1. General Precautions on Wiring

- (1) Before wiring, confirm the rated voltage of the unit as shown on its nameplate, then carry out the wiring closely following the wiring diagram under Section 4-3.



WARNING

- (2) This equipment is strongly recommended to be installed with Earth Leakage Circuit Breaker (ELCB) or Residual Current Device (RCD). Otherwise, it may cause electrical shock and fire in case of equipment breakdown or insulation breakdown.
The ELCB must be incorporated in the fixed wiring in accordance with the wiring regulations. The ELCB must be an approved circuit capacity, having a contact separation in all poles.
The ELCB or RCD suitable for use with inverters, resistant to high frequency noise, is most suitable. The ELCB's or RCD's intended for protection to include high frequency currents are unnecessary and should be avoided, as potentially causing nuisance tripping, in this application.
- (3) To prevent possible hazards from insulation failure, the unit must be grounded.
- (4) Each wiring connection must be done in accordance with the wiring system diagram. Wrong wiring may cause the unit to misoperate or become damaged.
- (5) Do not allow wiring to touch the refrigerant tubing, compressor, or any moving parts of the fan.
- (6) Unauthorized changes in the internal wiring can be very dangerous. The manufacturer will accept no responsibility for any damage or misoperation that occurs as a result of such unauthorized changes.
- (7) Regulations on wire diameters differ from locality to locality. For field wiring rules, please refer to your LOCAL ELECTRICAL CODES before beginning.
You must ensure that installation complies with all relevant rules and regulations.
- (8) To prevent malfunction of the air conditioner caused by electrical noise, care must be taken when wiring as follows:
 - The remote control wiring and the inter-unit control wiring should be wired apart from the inter-unit power wiring.
 - Use shielded wires for inter-unit control wiring between units and ground the shield on both sides.



CAUTION

Check local electrical codes and regulations before wiring. Also, check any specified instruction or limitations.

4-2. Wire Length and Wire Diameter for Power Supply System

Indoor unit

Type	(B) Power supply cable	Time delay fuse or circuit capacity
	Min. 2.5 mm ² *1	
F3	Max. 90 m *2	15 A

Control wiring

(C) Inter-unit (between outdoor and indoor units) control wiring	(D) Remote control wiring	(E) Remote control wiring for group control
Min. 0.75 mm ² Use shielded wiring *3	Min. 0.75 mm ²	Min. 0.75 mm ²
Max. 1,000 m	Max. 500 m	Max. 200 m (Total)

NOTE

*1 Maximum applicable wire for terminal board of indoor unit : 4 mm²

*2 Maximum length shows a 2% voltage drop.

*3 With ring-type wire terminal

4-3. Wiring System Diagrams

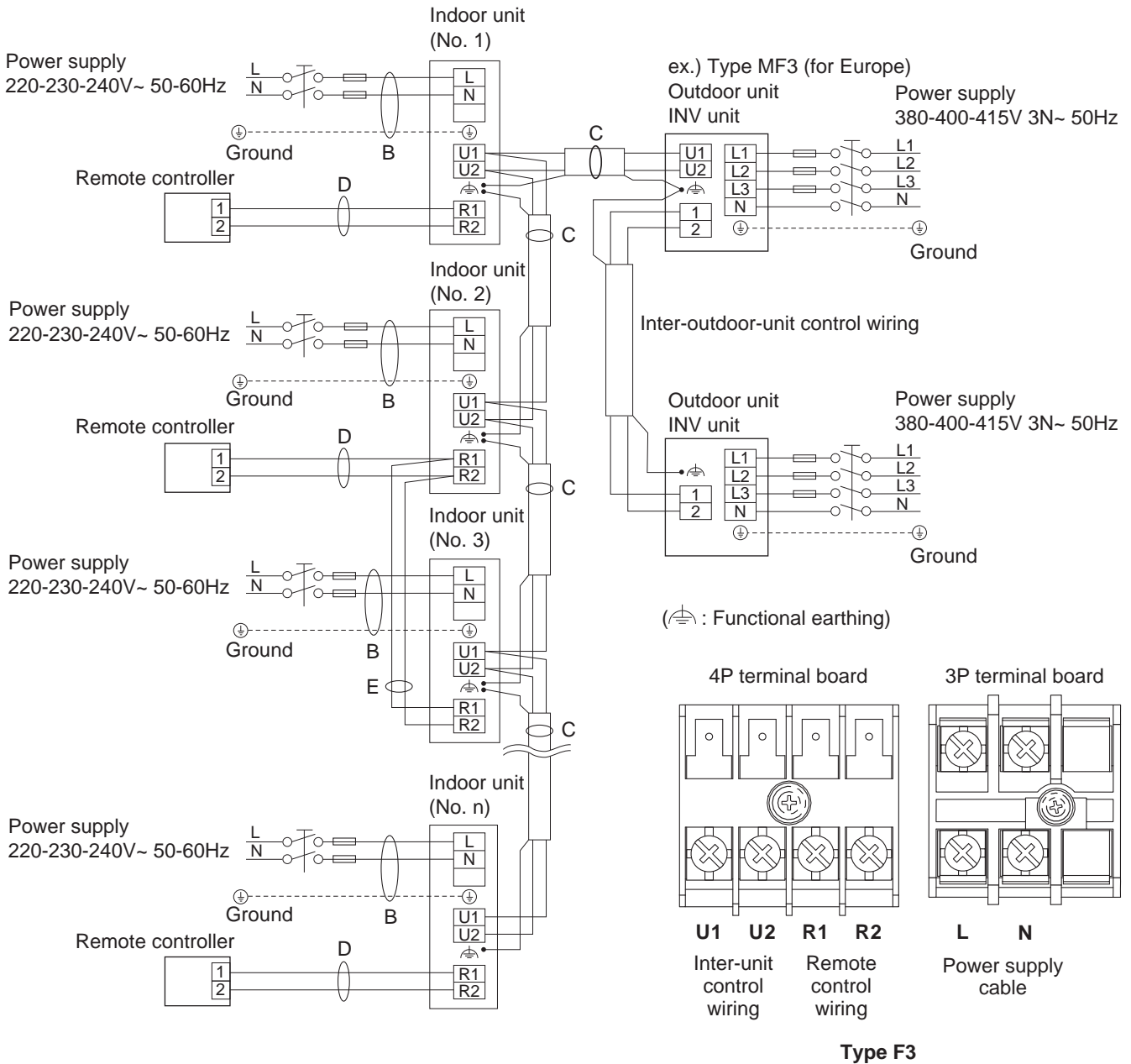

NOTE

- (1) See Section 4-2 for the explanation of “B”, “C”, “D” and “E” under Section 4-3.
- (2) The basic connection diagram of the indoor unit shows the terminal boards, so the terminal boards in your equipment may differ from the diagram.
- (3) Refrigerant Circuit address should be set before turning the power on.
- (4) Regarding Refrigerant Circuit address setting, refer to the installation instructions supplied with the remote controller (Optional). Auto address setting can be executed by remote controller automatically.

CAUTION

- (1) When linking the outdoor units in a network, disconnect the terminal extended from the short plug from all outdoor units except any one of the outdoor units.
 (When shipping: In shorted condition.)
 For a system without link (no wiring connection between outdoor units), do not remove the short plug.

- (2) Do not install the inter-unit control wiring in a way that forms a loop.

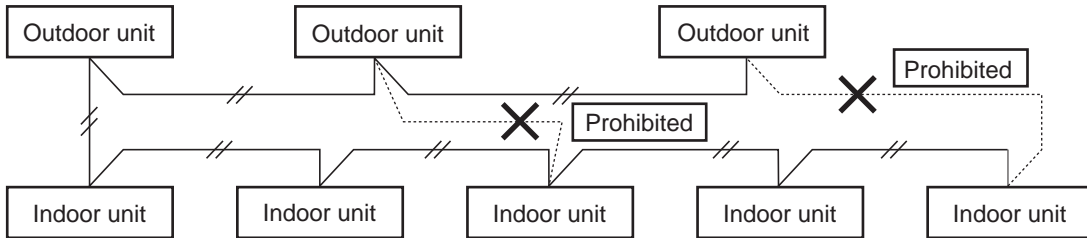

- (3) Do not install inter-unit control wiring such as star branch wiring. Star branch wiring causes mis-address setting.

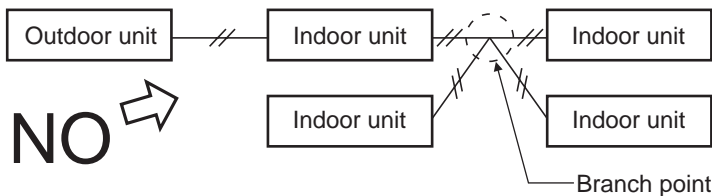

- (4) If branching the inter-unit control wiring, the number of branch points should be 16 or fewer.

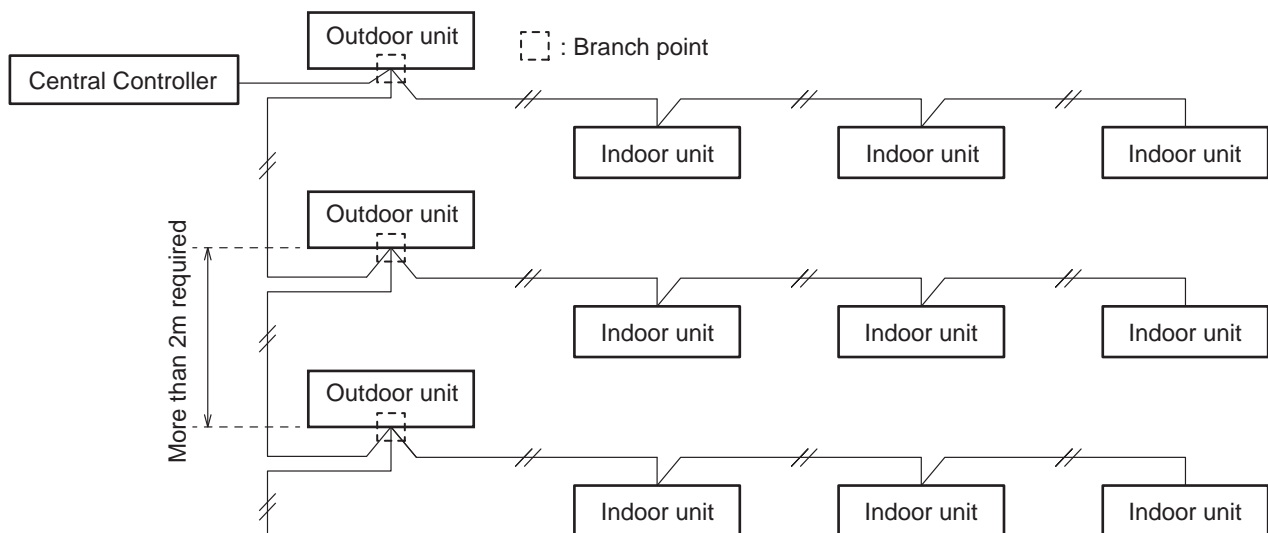

- (5) Use shielded wires for inter-unit control wiring (C) and ground the shield on both sides, otherwise misoperation from noise may occur. Connect wiring as shown in Section 4-3.

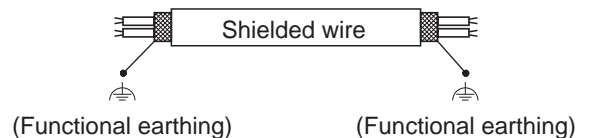

- (6) Use the standard power supply cables for Europe (such as H05RN-F or H07RN-F which conform to CENELEC (HAR) rating specifications) or use the cables based on IEC standard. (60245 IEC57, 60245 IEC66)

! WARNING

Loose wiring may cause the terminal to overheat or result in unit malfunction. A fire hazard may also occur. Therefore, ensure that all wiring is tightly connected.

When connecting each power wire to the terminal, follow the instructions on “How to connect wiring to the terminal” and fasten the wire securely with the terminal screw.

How to connect wiring to the terminal

■ For stranded wiring

- (1) Cut the wire end with cutting pliers, then strip the insulation to expose the stranded wiring about 10 mm and tightly twist the wire ends. Then attach the ring pressure terminal.
- (2) Using a Phillips head screwdriver, remove the terminal screw(s) on the terminal board.
- (3) Using a ring connector fastener or pliers, securely clamp each stripped wire end with a ring pressure terminal.
- (4) Place the ring pressure terminal, and replace and tighten the removed terminal screw using a screwdriver.

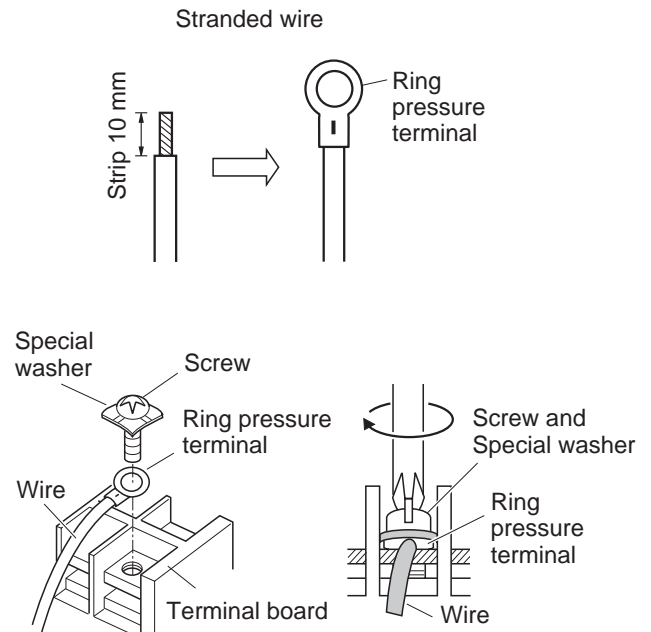

■ Examples of shield wires

- (1) Remove cable coat not to scratch braided shield.
- (2) Unbraid the braided shield carefully and twist the unbraided shield wires tightly together. Insulate the shield wires by covering them with an insulation tube or wrapping insulating tape around them.
- (3) Remove coat of signal wire.
- (4) Attach ring pressure terminals to the signal wires and the shield wires insulated in Step (2).

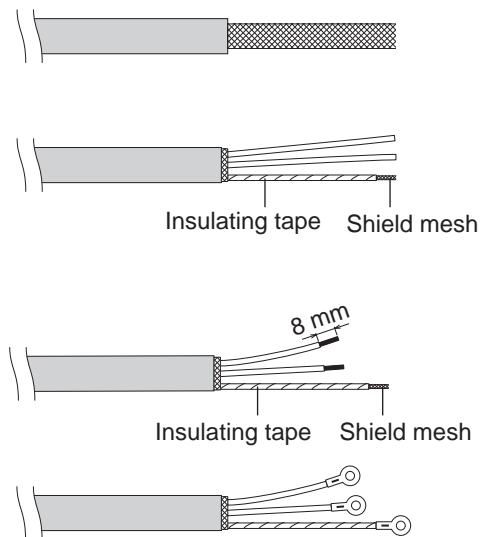

■ Wiring samples

Indoor unit (No. 2)

Use this screw when connecting the shield for the Inter-unit control wiring to ground.
 (⚡ : Functional earthing)

Earth wiring:
 Make the earth wiring 25 - 30 mm longer than connecting wires to L, N.

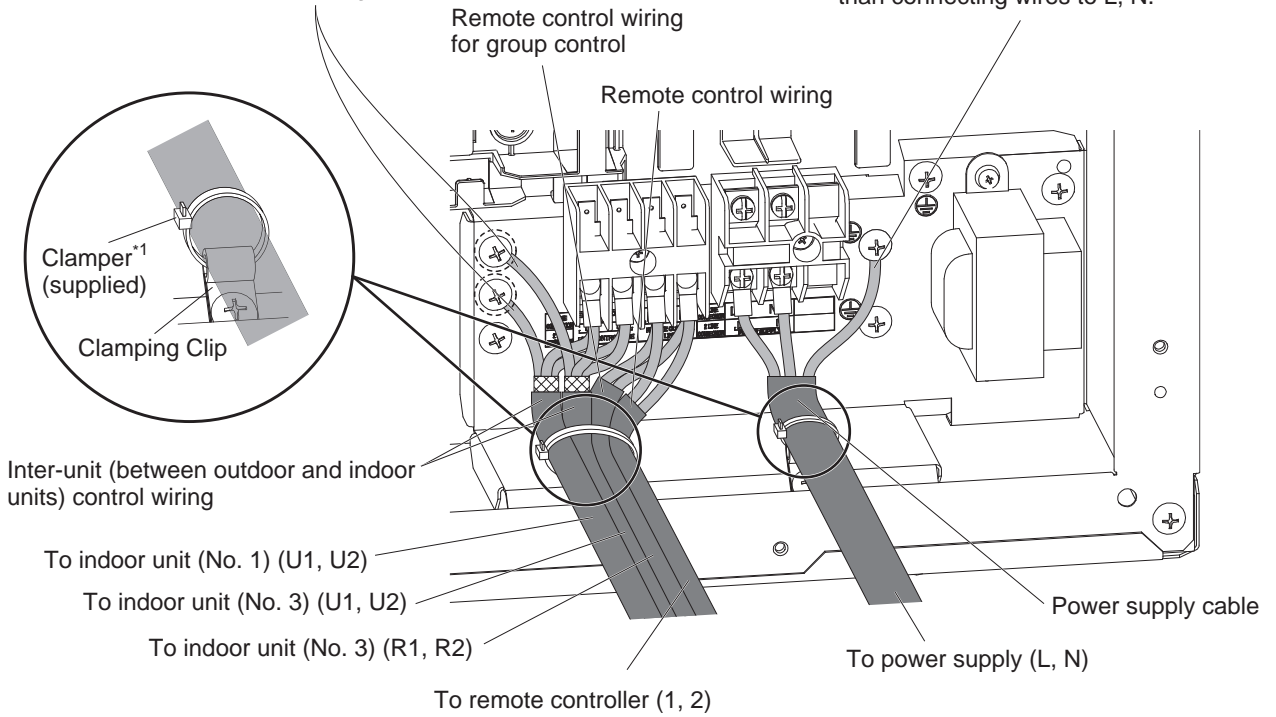

*1 Fasten tightly.

■ When connecting with 3WAY VRF outdoor unit

< In the case of Solenoid Valve Kit (CZ-P56HR3, CZ-P160HR3) + Solenoid Valve Controller (CZ-CAPE2) >

Read the Installation Instructions of Solenoid Valve Controller before installation.

1. Install the Solenoid Valve Control PCB as illustrated below.

NOTE: Be careful not to pinch the core and wiring when installing the Solenoid Valve Control PCB.

2. Make wiring as illustrated below.

(1) Make wiring the indoor unit control PCB and the Solenoid Valve Control PCB with using the below cables.

- Power cable (2 core) : Supplied with the Solenoid Valve Controller
- Signal output cable (short) : Supplied with the Solenoid Valve Controller

(2) Connect the Solenoid Valve Kit wire to the 9P connector of the Solenoid Valve Control PCB and the protective ground screw.

3. Make the wire binding as shown below.

(1) Bindings of the Power cable (2 cores) and the ground wire of the Solenoid Valve Kit: Use 2 clamps supplied with the indoor unit.

(2) Bindings of the power supply cable and the Solenoid Valve Kit wire: Use 2 cable ties supplied with the Solenoid Valve Controller.

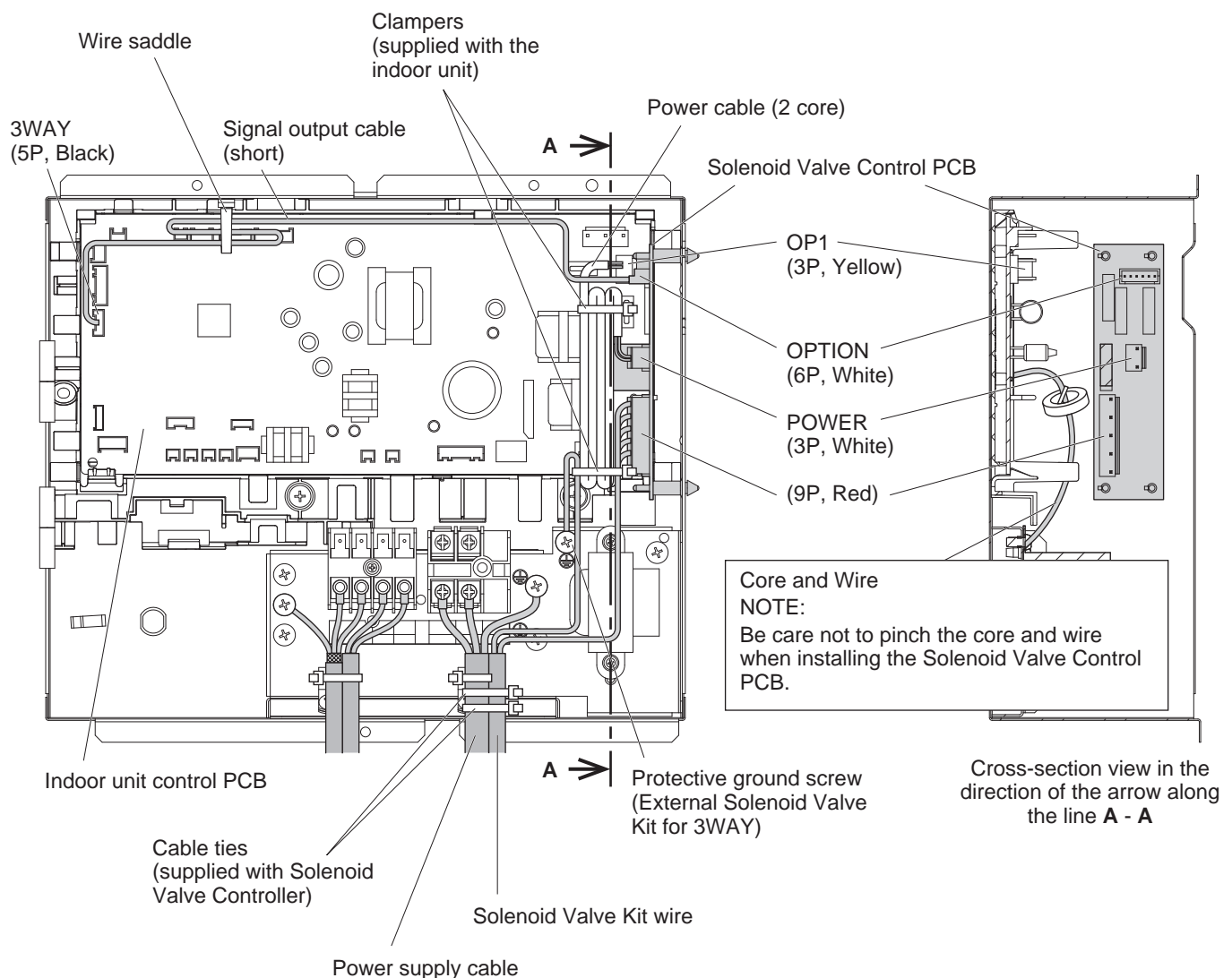

< In the case of Solenoid Valve Kit (CZ-P456HR3, CZ-P656HR3, CZ-P856HR3, CZ-P4160HR3) >

Read the Installation Instructions of Solenoid Valve Kit before installation.

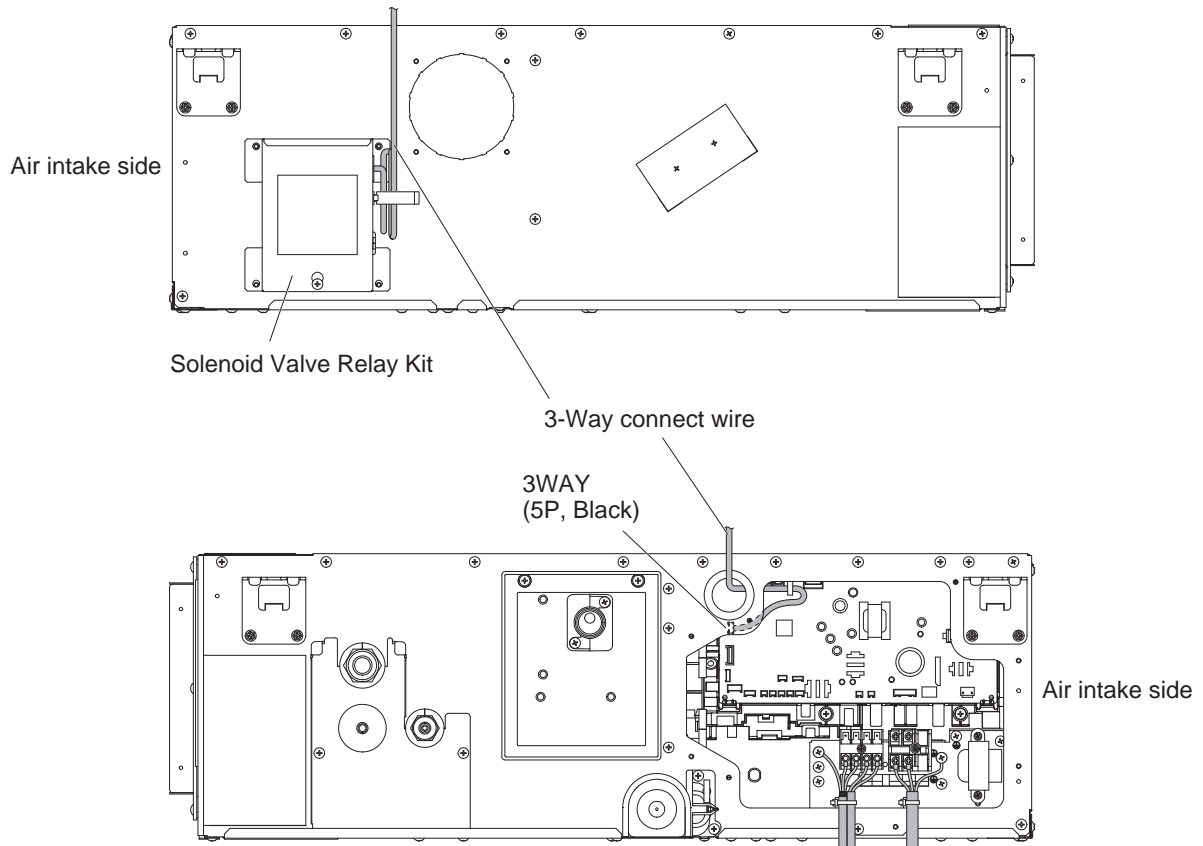

■ When connecting to the optional parts

< Connecting to Schedule Timer >

Read the Installation Instructions of Schedule Timer before installation.

1. Connect the inter-unit control wiring and Schedule timer communications wiring together.
2. Thread Schedule timer power wiring through the wire saddle and connect it to T10 connector.

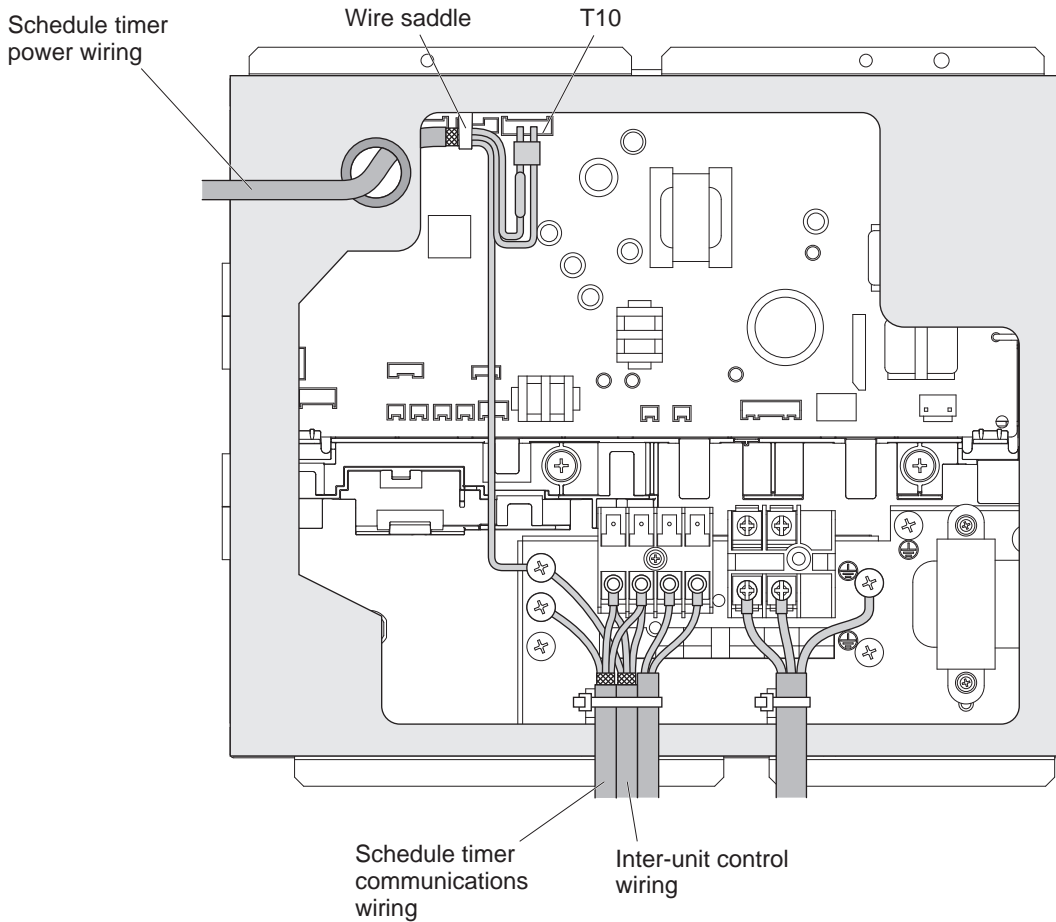

< Connecting to other optional parts >

Connect to each connector of the indoor unit control PCB as shown below.

NOTE:

Be sure to thread the wire through the wire saddle and connect to the connectors.

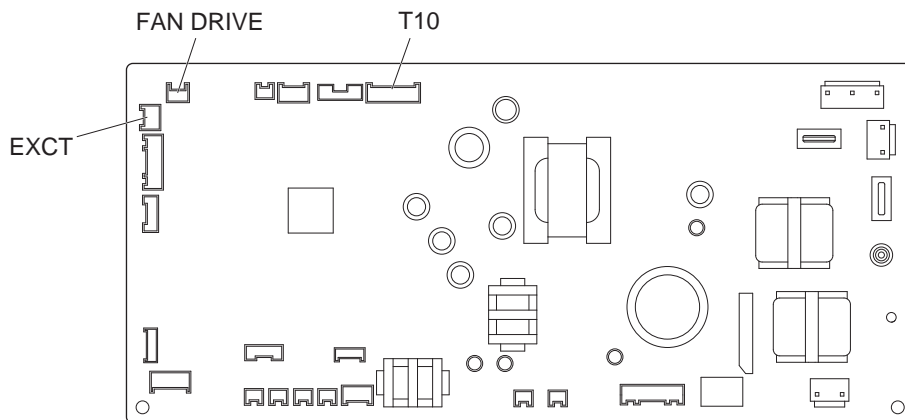

5. HOW TO PROCESS TUBING

5-1. Connecting the Refrigerant Tubing

Use of the Flaring Method

Many of conventional split system air conditioners employ the flaring method to connect refrigerant tubes that run between indoor and outdoor units. In this method, the copper tubes are flared at each end and connected with flare nuts.

Flaring Procedure with a Flare Tool

- (1) Cut the copper tube to the required length with a tube cutter. It is recommended to cut approx. 30 – 50 cm longer than the tubing length you estimate.
- (2) Remove burrs at each end of the copper tubing with a tube reamer or a similar tool. This process is important and should be done carefully to make a good flare. Be sure to keep any contaminants (moisture, dirt, metal filings, etc.) from entering the tubing.

NOTE

When reaming, hold the tube end downward and be sure that no copper scraps fall into the tube.

- (3) Remove the flare nut from the unit and be sure to mount it on the copper tube.
- (4) Make a flare at the end of the copper tube with a flare tool.

NOTE

A good flare should have the following characteristics:

- inside surface is glossy and smooth
- edge is smooth
- tapered sides are of uniform length

Caution Before Connecting Tubes Tightly

- (1) Apply a sealing cap or water-proof tape to prevent dust or water from entering the tubes before they are used.
 - (2) Use a small amount of ether oil (PVE only) to apply refrigerant lubricant to the inside of the flare nut when making a flare connection. Pay careful attention to prevent the ether oil (PVE only) from directly attaching the screw and resin parts. This is effective for reducing gas leaks.
 - (3) For proper connection, align the union tube and flare tube straight with each other, then screw on the flare nut lightly at first to obtain a smooth match.
- Adjust the shape of the liquid tube using a tube bender at the installation site and connect it to the liquid tubing side valve using a flare.

Deburring

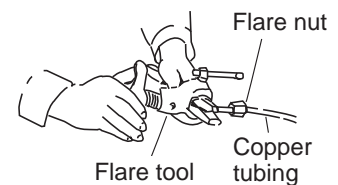
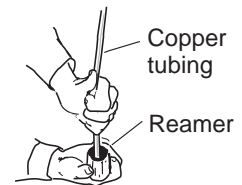
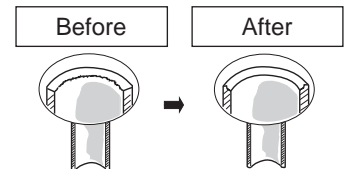

Apply a small amount of ether oil (PVE only) to the inside of the flare nut.

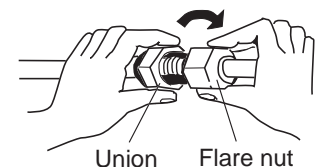

5-2. Connecting Tubing Between Indoor and Outdoor Units

NOTE

When connecting to the mini VRF 8HP, 10HP (outdoor units type LE1 only), select the main tube by using the following values. For details, refer to the installation instructions of the outdoor unit.

Indoor unit	15	22	28	36	45	56	60	73	90	106	112	140	160
Type F3	0.103						0.137			0.205			

- (1) Tightly connect the indoor-side refrigerant tubing extended from the wall with the outdoor-side tubing.

Indoor Unit Tubing Connection

Unit : mm

Indoor unit type	15	22	28	36	45	56	60	73	90	106	112	140	160
Gas tube	ø12.7						ø15.88						
Liquid tube	ø6.35						ø9.52						

- (2) To fasten the flare nuts, apply specified torque.

- When removing the flare nuts from the tubing connections, or when tightening them after connecting the tubing, be sure to use two spanners.
When tightening the flare nuts, use a torque wrench.
If the flare nuts are over-tightened, the flare may be damaged, which could result in refrigerant leakage and cause injury or asphyxiation to room occupants.
- For the flare nuts at tubing connections, be sure to use the flare nuts that were supplied with the unit, or else flare nuts for R410A (type 2). The refrigerant tubing that is used must be of the correct wall thickness as shown in the following table.
Because the pressure is approximately 1.6 times higher than conventional refrigerant R22 pressure, the use of ordinary flare nuts (type 1) or thin-walled tubes may result in tube rupture, injury, or asphyxiation caused by refrigerant leakage.
- In order to prevent damage to the flare caused by over-tightening of the flare nuts, use the following table as a guide when tightening.

Tube diameter	Tightening torque (approximate)	Tube thickness
ø6.35 (1/4")	14 – 18 N · m {140 – 180 kgf · cm}	0.8 mm
ø9.52 (3/8")	34 – 42 N · m {340 – 420 kgf · cm}	0.8 mm
ø12.7 (1/2")	49 – 61 N · m {490 – 610 kgf · cm}	0.8 mm
ø15.88 (5/8")	68 – 82 N · m {680 – 820 kgf · cm}	1.0 mm
ø19.05 (6/8")	100 – 120 N · m {1,000 – 1,200 kgf · cm}	1.0 mm

- When tightening the flare nut on the liquid tube, use an adjustable wrench with a nominal handle length of 200 mm.

5-3. Insulating the Refrigerant Tubing

Tubing Insulation

- Thermal insulation must be applied to all units tubing, including distribution joint (field supply).
 - * For gas tubing, the insulation material must be heat resistant to 120°C or above. For other tubing, it must be heat resistant to 80°C or above.

Insulation material thickness must be 10 mm or greater.

If the conditions inside the ceiling exceed DB 30°C and RH 70%, increase the thickness of the gas tubing insulation material by 1 step.

Two tubes arranged together

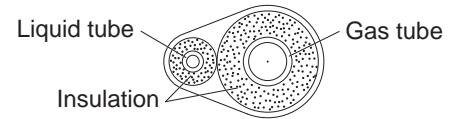

⚠ CAUTION

If the exterior of the outdoor unit valves has been finished with a square duct covering, make sure you allow sufficient space to access the valves and to allow the panels to be attached and removed.

Taping the flare nuts

Wind the insulating tape around the flare nuts at the gas / liquid tube connections. Then cover up the tubing connections with the flare insulator (supplied). Wrap with the flare insulator facing its seam upward.

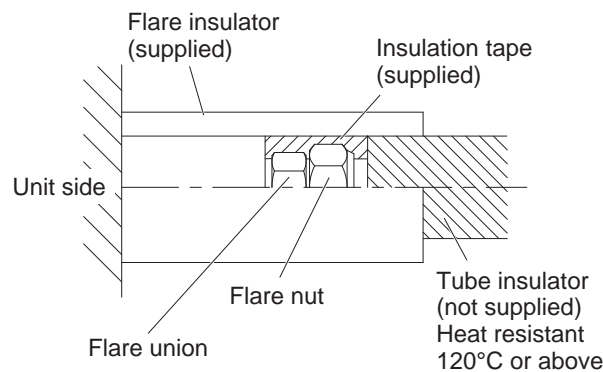

Insulation material

The material used for insulation must have good insulation characteristics, be easy to use, be age resistant, and must not easily absorb moisture.

NOTE

If noise bothers you from the area between indoor and outdoor units' connection pipes, it is effective to wind the soundproofing materials (field supply) to reduce noise.

⚠ CAUTION

After a tube has been insulated, never try to bend it into a narrow curve because it can cause the tube to break or crack.

Never grasp the drain or refrigerant connecting outlets when moving the unit.

5-4. Taping the Tubes

- (1) At this time, the refrigerant tubes (and electrical wiring if local codes permit) should be taped together with armoring tape in 1 bundle. To prevent condensation from overflowing the drain pan, keep the drain hose separate from the refrigerant tubing.
- (2) Wrap the armoring tape from the bottom of the outdoor unit to the top of the tubing where it enters the wall. As you wrap the tubing, overlap half of each previous tape turn.
- (3) Clamp the tubing bundle to the wall, using 1 clamp approx. each meter.

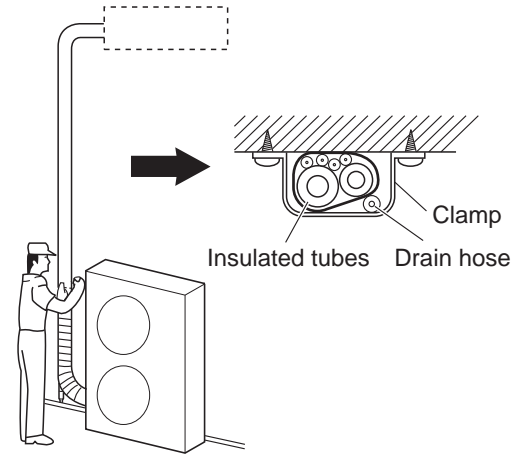

NOTE

Do not wind the armoring tape too tightly since this will decrease the heat insulation effect. Also ensure that the condensation drain hose splits away from the bundle and drips clear of the unit and the tubing.

5-5. Finishing the Installation

After finishing insulating and taping over the tubing, use sealing putty to seal off the hole in the wall to prevent rain and draft from entering.

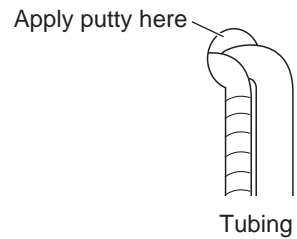

6. HOW TO INSTALL THE TIMER REMOTE CONTROLLER OR HIGH-SPEC WIRED REMOTE CONTROLLER (OPTIONAL PART)

NOTE

Refer to the Installation Instructions attached to the optional Timer Remote Controller or optional High-spec Wired Remote Controller.

7. HOW TO INSTALL WIRELESS REMOTE CONTROLLER

NOTE

Refer to the Installation Instructions attached to the optional Wireless Remote Controller.

8. PRECAUTIONS ON TEST RUN

- Request that the customer be present when the test run is performed. At this time, explain the operation manual and have the customer perform the actual steps.
- Check that the 220 – 240 VAC power is not connected to the inter-unit control wiring connector terminal.

* If 220 – 240 VAC is accidentally applied, the indoor unit control PCB fuse will blow in order to protect the PCB. In this case, make the wiring correctly. Then disconnect the 2P connectors (OC) that are connected to the indoor unit control PCB, and replace them with 2P connectors (EMG).

If operation is still not possible after changing the brown connectors, cut off the jumper on the indoor unit control PCB.

(Be sure to turn the power OFF before performing this work.)

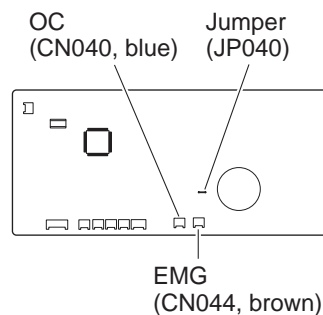

9. CHECKLIST AFTER INSTALLATION WORK

Work List	No.	Content	Check <input checked="" type="checkbox"/>	Possibility of Failure & Checkpoint	
Installation	1	Are the indoor units installed following the content of Section "2. SELECTING THE INSTALLATION SITE"?	<input type="checkbox"/>	There is a possibility of light injure or loss of property.	
Tubing & Wiring	2	In the case of multiple installation: Is there a wrong tubing connection with another system?	<input type="checkbox"/>	The unit is inoperated or the refrigerant flows into the inoperative unit and the leakage is expected. Check if there is a wrong tubing or wiring connection with another system.	
	3	In the case of multiple installation: Is there a wrong wiring connection with another system?	<input type="checkbox"/>		
	4	Is the earth leakage circuit breaker (all-pole switching function provided) installed?	<input type="checkbox"/>	Power failure or short circuit may cause electric shock or fire. Check installation work and ground wire work.	
	5	Is there any wrong installation of optional parts or wrong wiring?	<input type="checkbox"/>		
	6	Was the ground wire work performed?	<input type="checkbox"/>		
	7	Are there any wrong power supply wiring, wrong connection wire, wrong signal wire or loose screw?	<input type="checkbox"/>		
	8	Is the thickness of wire in accordance with rule?	<input type="checkbox"/>		
	9	Is the power-supply voltage equal to the nameplate of the unit?	<input type="checkbox"/>		
	10	Was the check of the airtight test, flared tube fitting and gas leakage on the welded portion performed?	<input type="checkbox"/>		If the gas leakage occurs, the unit quality not only becomes inferior but affects environment. Repair it as quickly as possible.
	Drain Check	11	Has the adhesive been applied to the drain connecting portion (resin portion) of the indoor unit?		<input type="checkbox"/>
12		Is there water leakage?	<input type="checkbox"/>	Since there is a possibility of water drain, repair the drain pipe if the drain failure or water drain occurs.	
13		Indoor unit drain pipe has a downward gradient (1/100 or more) by rule. Is the drain water flowing smoothly?	<input type="checkbox"/>		
Heat Insulation	14	Was the heat insulation work at a suitable location including the flared tube fitting (refrigerant tube & drain pipe) performed properly?	<input type="checkbox"/>	The quality of unit not only becomes inferior but there is a possibility of the water drain. So, perform the heat insulation work properly.	
Test Run	15	Did the abnormal sound occur?	<input type="checkbox"/>	Check if there is a fan contact or distortion of the indoor unit.	
	16	Did the cool and warm airflow discharge from the indoor unit?	<input type="checkbox"/>	Check if the unit does not operate or there is a wrong tubing or wiring connection with another system.	

10. EXTERNAL STATIC PRESSURE SETTING

For middle static pressure duct type indoor units, the ventilating resistance so-called “external static pressure” becomes greatly different depending on the connected duct length, shape, number of air outlet ports and types of filters.

When installing this unit, be sure to carry out the external static pressure setting in order to operate in the rated airflow volume.

Choose one of the following methods from “a”, “b”, “c” or “d” as shown in the flow chart (within the dotted lines) and then make the setting accordingly.

a. No setting modification:

Use-as-is at shipment (there are cases in which the setting may differ from the shipment setting when reset after once setting the external static pressure.)

b. Manual setting (set with the indoor unit control PCB):

For high static pressure. Switching method with the short-circuit connector.

c. Manual setting (set with the wired remote controller):

Low static pressure ~ high static pressure

d. Auto airflow volume setting (set on the wired remote controller):

Air outlet volume is automatically adjusted to the rated airflow volume with the auto airflow volume control operation.

Flow of External Static Pressure

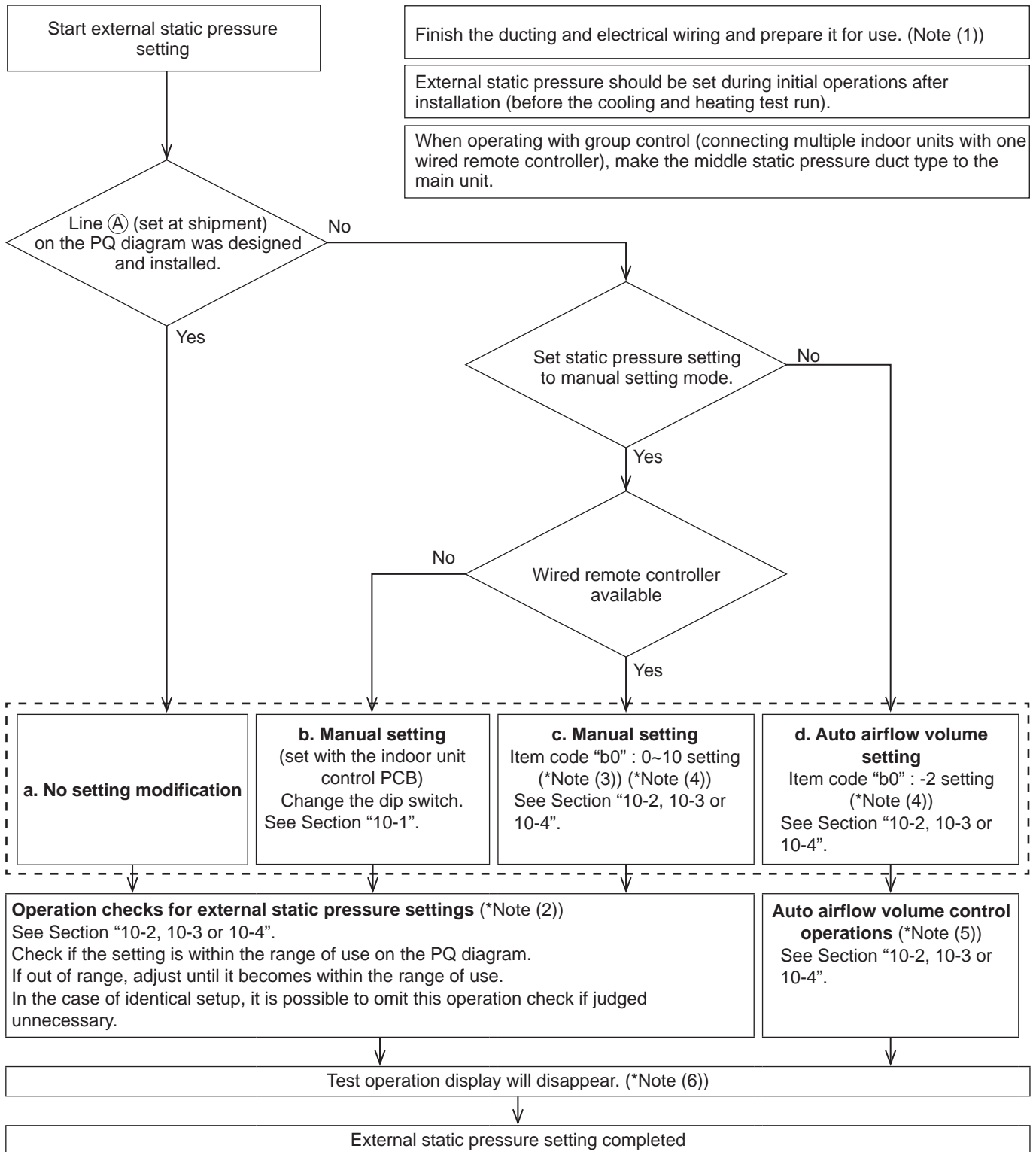

NOTE

- (1) Check the following items before performing the setting-check operations or auto airflow volume operations.
- 1) Check to make sure that the electrical wiring and ducting have been completed. Activate the stand-by mode. In particular, make sure that the closed damper located in the middle of the duct is open, if installed. Also, make sure that air filters have been installed inside the air inlet duct.
Check to make sure air is not leaking from the joints.

- 2) If multiple air outlets and air inlets are included, adjust the airflow volume ratio of all of them until they meet the design airflow ratio.
- 3) Make sure the address setting has been completed.
- (2) The operation check will be completed in approximately three minutes if the settings have been made correctly. The settings will be modified if they are out of the range of use (maximum 30 minutes). If this is not completed within 31 minutes, check whether the air speed is set to "H" or not.
- (3) See Table 10-2, 10-3 or 10-4 and Fig. 10-2 for details on the relationship between the value of item code "b0" and the external static pressure.
- (4) When set in group control (connecting multiple indoor units with one wired remote controller), set each indoor unit to item code "b0".
When amending the setting after selecting [b. Manual setting] (due to airflow path changes, etc.), it is necessary to cancel [b. Manual setting] (change the dip switch). When [b. Manual setting] has not been cancelled, [c. Manual setting] and [d. Auto airflow volume setting] will be activated if selected, but [b. Manual setting] takes precedence when the power is switched back on after power outages, etc.
- (5) If this is not completed within 8 minutes, check the operation mode, air speed and air inlet temperature.
- (6) When set in group control (connecting multiple indoor units with one wired remote controller), the test run operations display will disappear once the external static pressure setting check or auto airflow volume control operation check have been completed for the main unit. However, it is not possible to determine whether sub-units have completed. The test run operation display will disappear after one hour even if the external static pressure setting check or auto airflow volume control operation check have not been completed.

 **CAUTION**

- **Be sure to check that the external static pressure is within the range for use and then make the setting. Failure to observe this may result in insufficient airflow or water leakages. See Fig. 10-2 for the external static pressure setting range.**
- **There are cases in which automatic variable dampers and other mounted items may trigger the P12 alarm on systems that modify the external static pressure when the auto airflow volume control operations or setting check operations are carried out if high external static pressure is lowered. In this event, lower the dampers, etc., so that the external static pressure reaches its lowest level, and then carry out the auto airflow volume control operations or setting check operations.**
- **Be sure to set the [External Static Pressure Setting] once again after amending the airflow path for the duct or air outlet after setting the external static pressure.**
- **Set the air inlet temperature within the range for use. The auto airflow volume control will not function if the air inlet temperature is over 45°C or if operation is other than fan mode.**

10-1. How to Set on Indoor Unit Control PCB

1. Turn off the power breaker to halt the supply of electricity to the indoor unit control PCB.
2. Open the electrical component box cover, then check the indoor unit control PCB.
(Fig. 10-1)
3. Change the dip switch (SW001) of the indoor unit control PCB according to the setting selected in Table 10-1.

Table 10-1

External static pressure of the rated airflow volume	DIP switch
10 Pa	
40 Pa (Type 90, 106)	
50 Pa (Type 15, 22, 28, 36, 45, 56, 60, 73, 112, 140, 160)	
110 Pa	

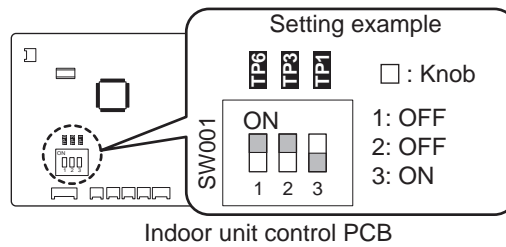





Fig. 10-1





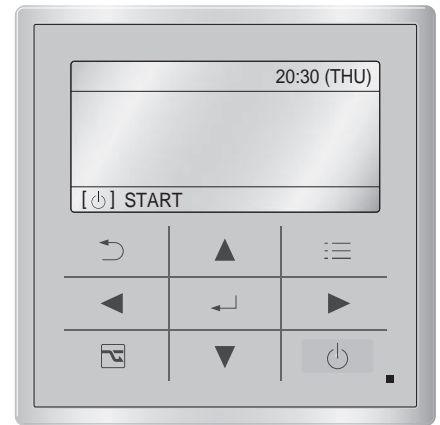

10-2. Operating the High-spec Wired Remote Controller (CZ-RTC5B)

How to set the external static pressure

- Keep pressing the ,  and  buttons simultaneously for 4 or more seconds. The “Maintenance func” screen appears on the LCD display.





 Maintenance func	20:30 (THU)
1. Outdoor unit error data	
2. Service contact	
3. RC setting mode	
4. Test run	
◀ Sel. ▶ Page [↵] Confirm	







- Press the  or  button to see each menu. If you wish to see the next screen instantly, press the  or  button. Select “8. Detailed settings” on the LCD display and press the  button. The “Detailed settings” screen appears on the LCD display.
- Select the “Unit no.” by pressing the  or  button for changes.

 Maintenance func	20:30 (THU)
5. Sensor info.	
6. Servicing check	
7. Simple settings	
8. Detailed settings	
◀ Sel. ▶ Page [↵] Confirm	

Detailed settings		20:30 (THU)
Unit no.	Code no.	Set data
1-1	10	0005
◀ Sel. ▶ Next		

- Select the “Code no.” by pressing the  or  button. Change the “Code no.” to “B0” by pressing the  or  button (or keeping it pressed).

Detailed settings		20:30 (THU)
Unit no.	Code no.	Set data
1-1	B0	-001
◀ Sel. ▶ Next		

- Select the “Set data” by pressing the  or  button. Select one of the “Set data” among “0001” – “0010” according to the desired external static pressure setting by pressing the  or  button. Then press the  button.

Detailed settings		20:30 (THU)
Unit no.	Code no.	Set data
1-1	B0	0001
◀ Sel. [↵] Confirm		

(See Table 10-2.)

When setting to auto airflow volume control:

Select the setting data to “-002”.

Then press the  button.

Detailed settings		20:30 (THU)
Unit no.	Code no.	Set data
1-1	B0	-002
◀ Sel. [↵] Confirm		

Table 10-2 Setting the external static pressure

Indoor unit type			Item code
15, 22, 28, 36, 45, 56, 60, 73	90, 106	112, 140, 160	B0
External static pressure of the rated airflow volume (Pa)			
150	150	150	
140	140	140	
130	130	130	
120	120	120	
110	110	110	
90	90	90	
70	70	70	
50	40 *	50 *	
30 *	30	30	
10	10	10	
No auto airflow volume setting			-001
Auto airflow volume setting			-002

* Airflow volume setting at shipment

NOTE:

Failure to set this parameter may result in decreased airflow and condensation.

- Select the “Unit no.” by pressing the or button and press the button.
The “Exit detailed settings and restart?” (Detailed setting-end) screen appears on the LCD display.
Select “YES” and press the button.
When the setting is completed, perform the test run for the external static pressure setting described in “Auto External Static Pressure Setting Operation”.

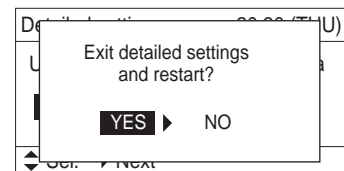

Auto External Static Pressure Setting Operation

- Keep pressing the , , and buttons simultaneously for 4 or more seconds.
The “Maintenance func” screen appears on the LCD display.
- Press the or button to see each menu.
If you wish to see the next screen instantly, press the or button.
Select “4. Test run” on the LCD display and press the button.
The “Test run” screen appears on the LCD display.

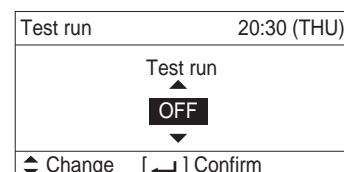
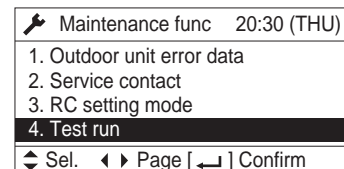
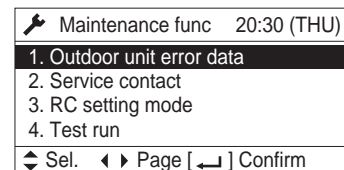



Change the display from “OFF” to “ON” by pressing the

 or  button.

Then press the  button.

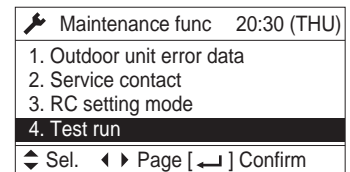
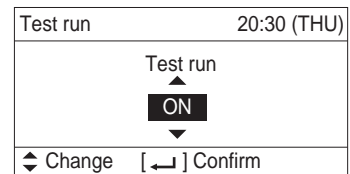
The “Maintenance func” screen appears on the LCD display.





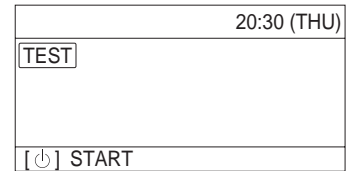

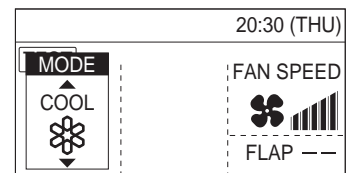

9. Press the  button. “TEST” will be displayed on the LCD display.



10. Press the  button. Test run will be started. Test run setting mode screen appears on the LCD display.



11. Set the operation mode to “ (MODE FAN)” and fan speed mode to “ (FAN SPEED)” by pressing the  or  button or  or  button. Then press the  button.

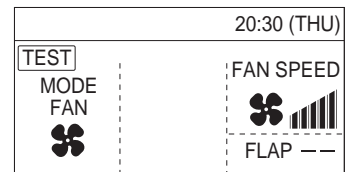

The fan motor will be activated, the auto external static pressure setting operation and setting-check operation will be performed for about 3 to 30 minutes. The fan speed will change automatically while these operations are in progress. When these operations completed, “TEST” will be disappeared from the LCD display.

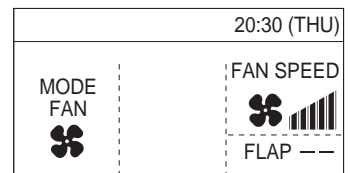

NOTE:

The auto external static pressure setting operation and setting-check operation will not be performed unless “ (MODE FAN)” and “ (FAN SPEED)” have been selected.

12. Press the  button. The LCD display will be returned to the initial screen.

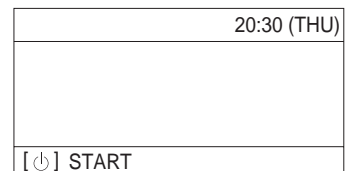











NOTE:

Failure to set this parameter may result in decreased airflow and condensation.

10-3. Operating the Timer Remote Controller (CZ-RTC4)

10-3-1. Setting Item Code “b0”

- Press and hold down the ,  and  buttons simultaneously for 4 or more seconds.
(**SETTING**, the unit no., item code and detailed data will blink on the LCD display.)
- The indoor unit numbers in the group control will be sequentially displayed whenever the Unit Select button is pressed .
Only the fan motor for the selected indoor unit will operate during this time.
- Specify the “b0” item code by pressing the  /  buttons for the temperature setting buttons and confirm the values.
(“-001” set at shipment)
- Press the  /  buttons for the time to amend the values for the set data.
See Table 10-3 and Fig. 10-2 and select a value between “0001” and “0010”.
Select “-002” if the auto airflow volume setting is activated.
- Press the  button.
The display will stop blinking and remain illuminated.
- Press the  button. The fan motor will stop operating and the LCD display will return to the normal stop mode.

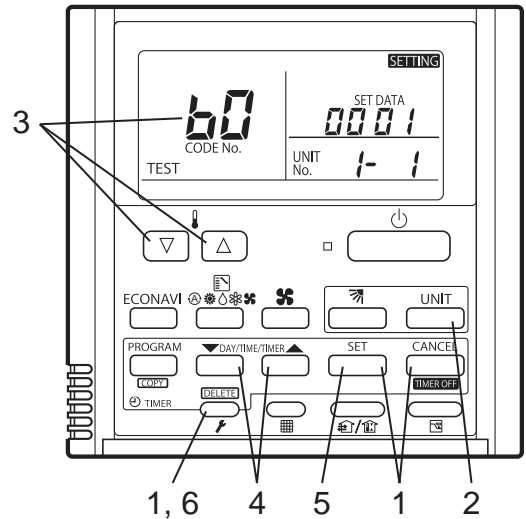

Table 10-3 Setting the external static pressure







Indoor unit type			Item code
15, 22, 28, 36, 45, 56, 60, 73	90, 106	112, 140, 160	b0
External static pressure of the rated airflow volume (Pa)			
150	150	150	0010
140	140	140	0009
130	130	130	0008
120	120	120	0007
110	110	110	0006
90	90	90	0005
70	70	70	0004
50	40 *	50 *	0003
30 *	30	30	0002
10	10	10	0001
No auto airflow volume setting			-001
Auto airflow volume setting			-002

* Airflow volume setting at shipment

NOTE:

Failure to set this parameter may result in decreased airflow and condensation.

10-3-2. Auto Airflow Volume Control Operations and External Static Pressure Setting-Check Operation

1. Press and hold down the  button for 4 or more seconds. "TEST" will be displayed on the LCD display.
2. Press the  button to start the test run.
3. Select the operation mode  (Fan) by pressing the  (Mode select) button. Then select the fan speed  by pressing the  (Fan speed) button.

NOTE

Auto airflow volume control operations and external static pressure setting-check operations will not be performed unless the above settings are made.

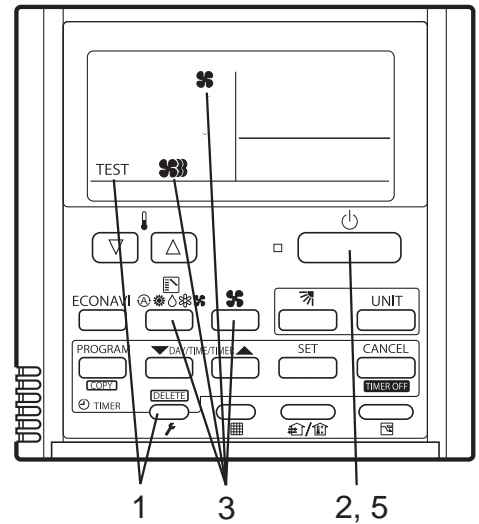



4. The fan motor will be activated and auto airflow volume control operations or external static pressure setting-check operations will be started.
The power of the airflow will change while these operations are in progress.
The external static pressure setting-check operations and auto airflow volume control operations will be completed in about 3 to 30 minutes.
"TEST" display will be disappeared from the LCD display.
5. Press the  button to halt the test run.



10-4. Operating the Wired Remote Controller (CZ-RTC6 series)

Stop the system before performing these steps.



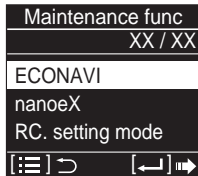









How to set the external static pressure

- Keep pressing the ,  and  buttons simultaneously for 4 or more seconds.
The “Maintenance func” screen appears on the LCD display.



- Press the  or  button to see each menu.
Select “Detailed settings” on the LCD display and press the  button.

The “Detailed settings” screen appears on the LCD display.

- Select the “Unit no.” by pressing the  or  button.
After selecting “Unit no.”, press the  button and proceed to Step 4.
- Select the “Code no.” by pressing the  or  button.
Change the “Code no.” to “0000B0” by pressing the  or  button (or keeping it pressed).
After selecting “Code no.”, press the  button and proceed to Step 5.
- Select the “Set data” by pressing the  or  button.
Select one of the “Set data” among “0001” – “0010” according to the desired external static pressure setting by pressing the  or  button.
After selecting “Set data”, press the  button. (If setting continuously, follow the procedures from Step 3.)
(See Table 10-4.)

When setting to auto airflow volume control:

Select the setting data to “-002”.

After selecting “Set data”, press the  button. (If setting continuously, follow the procedures from Step 3.)

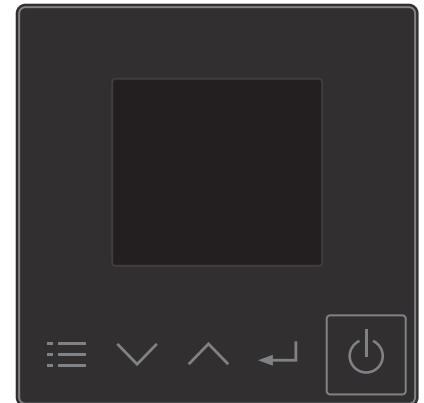

Black

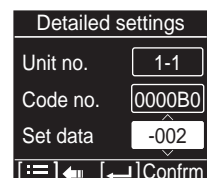
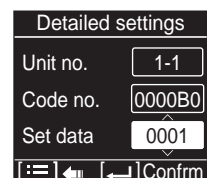
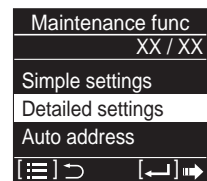





Table 10-4 Setting the external static pressure

Indoor unit type			Item code
15, 22, 28, 36, 45, 56, 60, 73	90, 106	112, 140, 160	B0
External static pressure of the rated airflow volume (Pa)			
150	150	150	
140	140	140	
130	130	130	
120	120	120	
110	110	110	
90	90	90	
70	70	70	
50	40 *	50 *	
30 *	30	30	
10	10	10	
No auto airflow volume setting			
Auto airflow volume setting			-002

* Airflow volume setting at shipment







NOTE:

Failure to set this parameter may result in decreased airflow and condensation.

- If the  button is pressed under the display Step 3, the following display (Detailed setting-end screen) appears.
Then select “YES” by pressing the  or  button and press the  button.





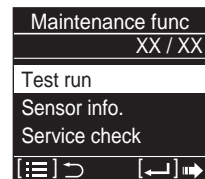
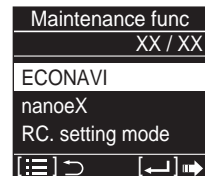

Auto External Static Pressure Setting Operation

- Keep pressing the ,  and  buttons simultaneously for 4 or more seconds.
The “Maintenance func” screen appears on the LCD display.
- Press the  or  button to see each menu.
Select “Test run” on the LCD display and press the  button.

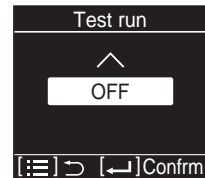

The “Test run” screen appears on the LCD display.



- Change the display from “OFF” to “ON” by pressing the  or  button.
Then press the  button.



The “Maintenance func” screen appears on the LCD display.

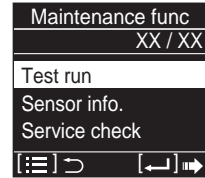

- 9. Press the button.
“TEST” will be displayed on the LCD display.



- 10. Press the button. Test run will be started.
Test run setting mode screen appears on the LCD display.
Current fan speed can be checked by pressing the button.



- 11. Set the operation mode to “ (MODE FAN)” and fan speed mode to “ (FAN SPEED)” by pressing the and or buttons.
Then press the button.

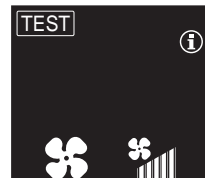

The fan motor will be activated, the auto external static pressure setting operation and setting-check operation will be performed for about 3 to 30 minutes.
The fan speed will change automatically while these operations are in progress.
When these operations completed, “TEST” will be disappeared from the LCD display.

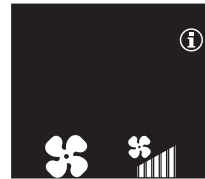

NOTE:
Failure to set this parameter may result in decreased airflow and condensation.

NOTE

The wired remote controller illustrated below can also be available following the same procedures as above.

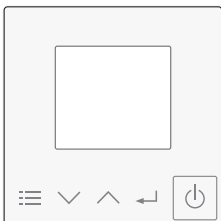

White

Indoor Units Type 15, 22, 28

Indoor Fan Performance

PQ diagram (Fig. 10-2)

External static pressure 150Pa, 90Pa

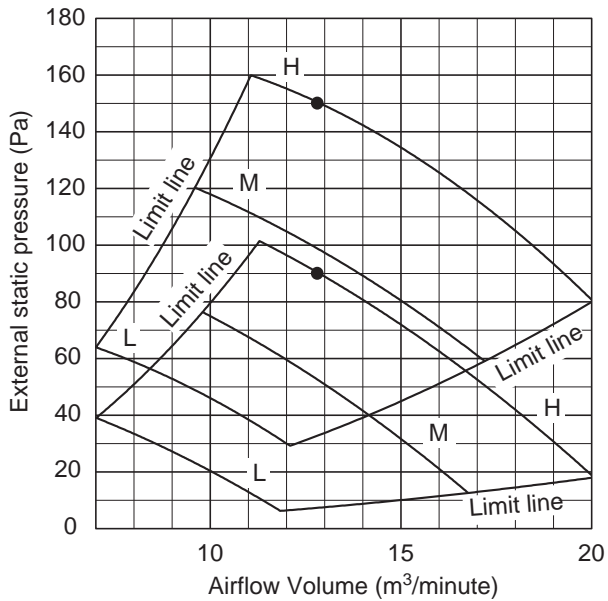

External static pressure 140Pa, 70Pa

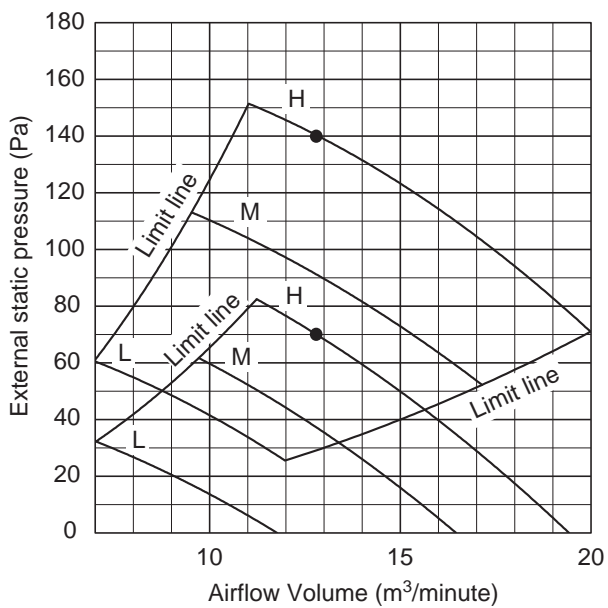

External static pressure 130Pa, 50Pa

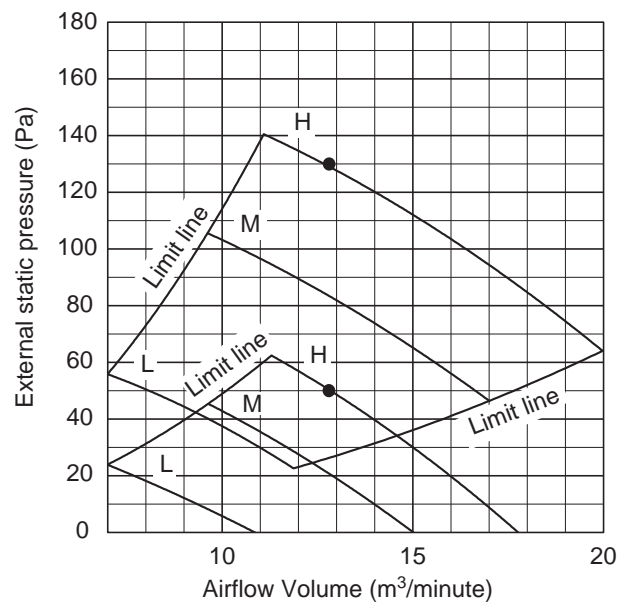

External static pressure 120Pa, 30Pa

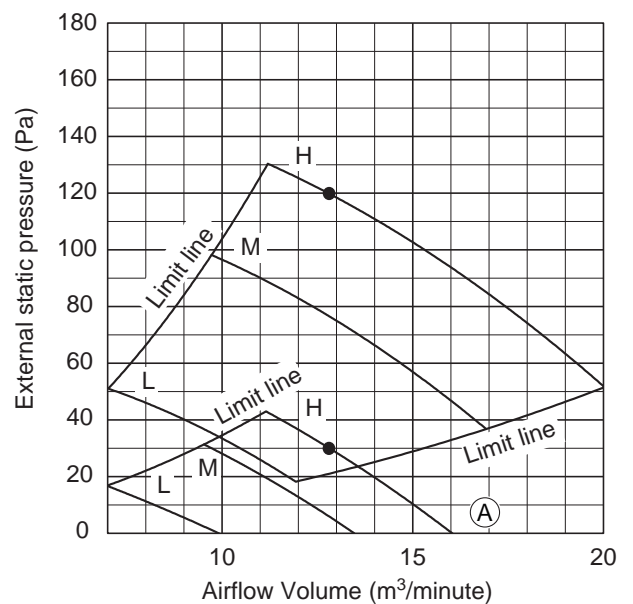

External static pressure 110Pa, 10Pa

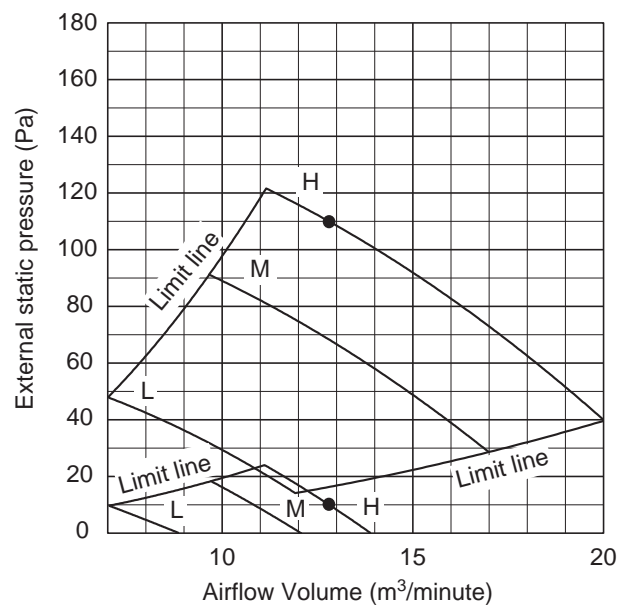

Indoor Units Type 36, 45

Indoor Fan Performance

PQ diagram (Fig. 10-2)

External static pressure 150Pa, 90Pa

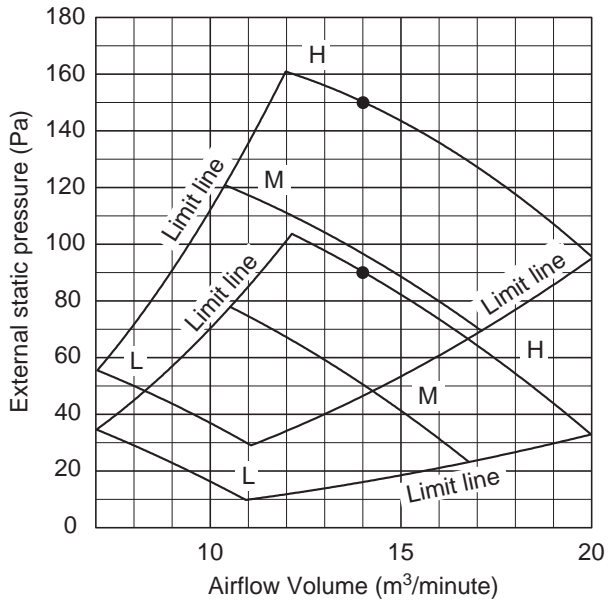

External static pressure 140Pa, 70Pa

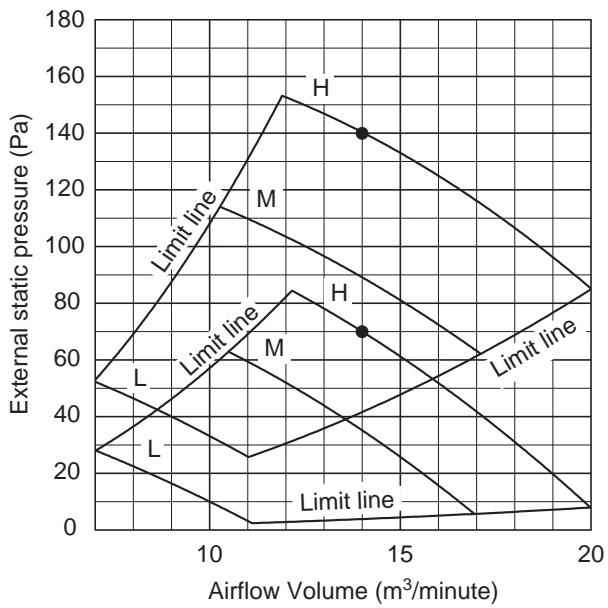

External static pressure 130Pa, 50Pa

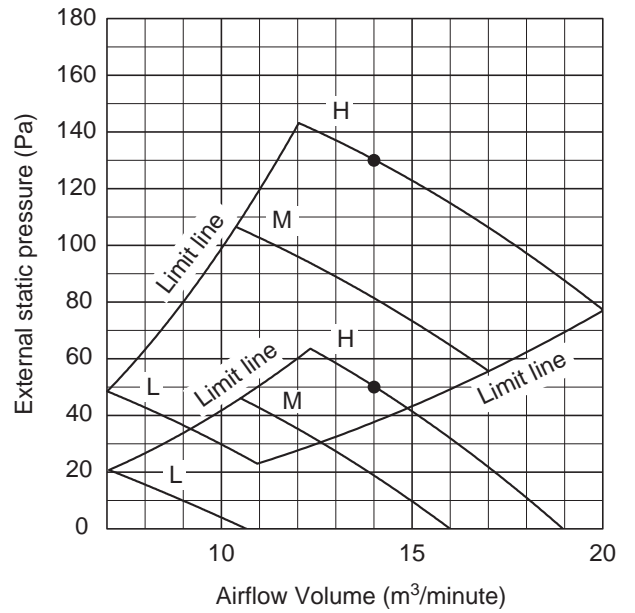

External static pressure 120Pa, 30Pa

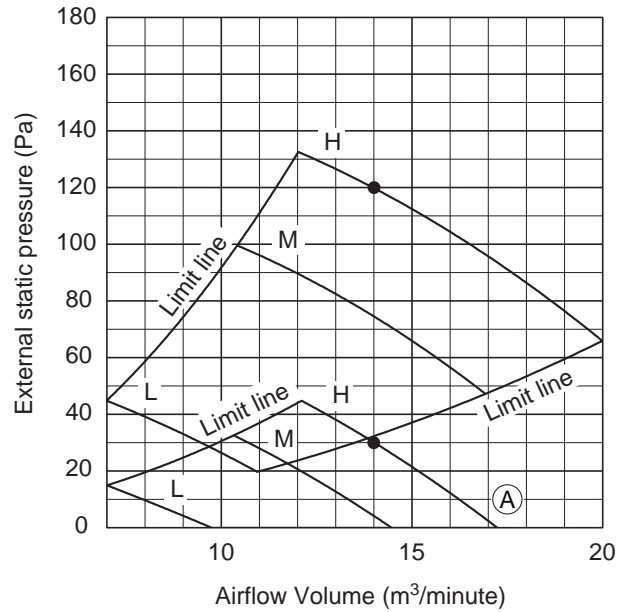

External static pressure 110Pa, 10Pa

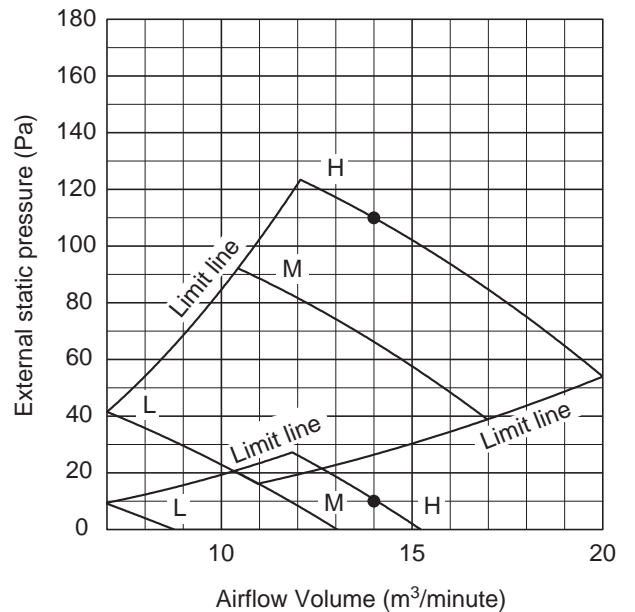

Indoor Units Type 56

Indoor Fan Performance

PQ diagram (Fig. 10-2)

External static pressure 150Pa, 90Pa

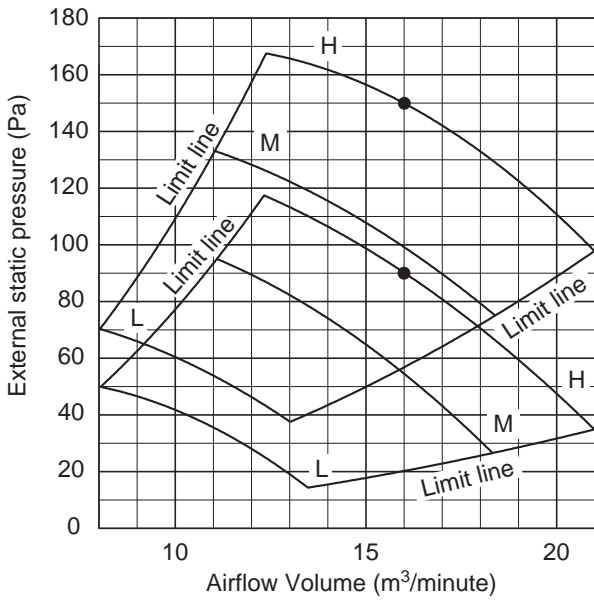

External static pressure 140Pa, 70Pa

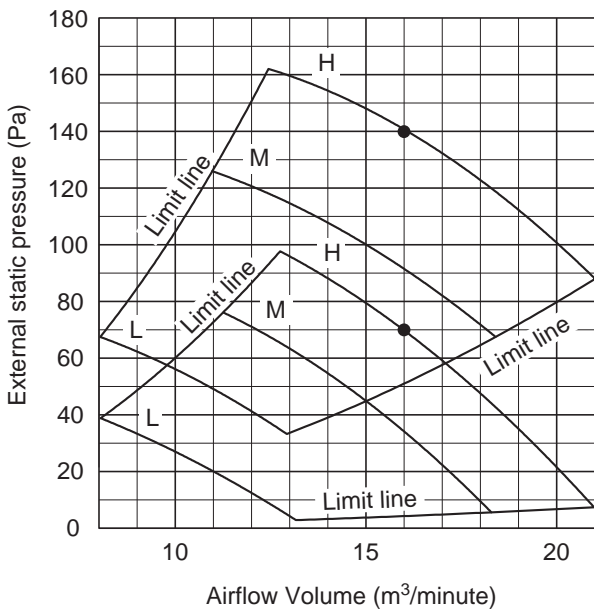

External static pressure 130Pa, 50Pa

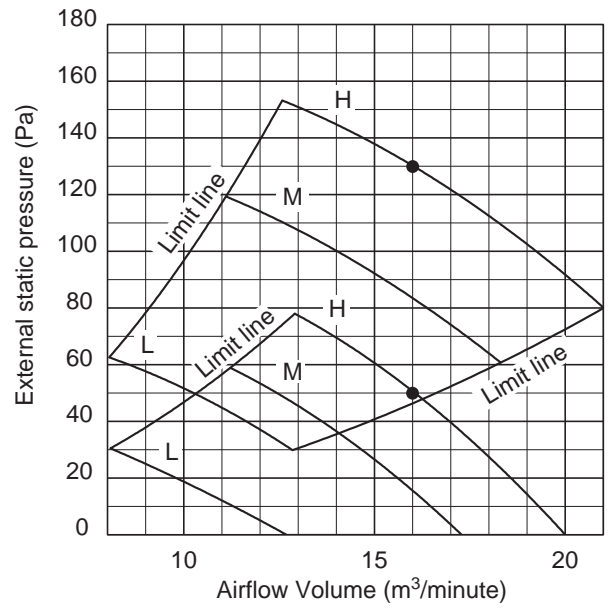

External static pressure 120Pa, 30Pa

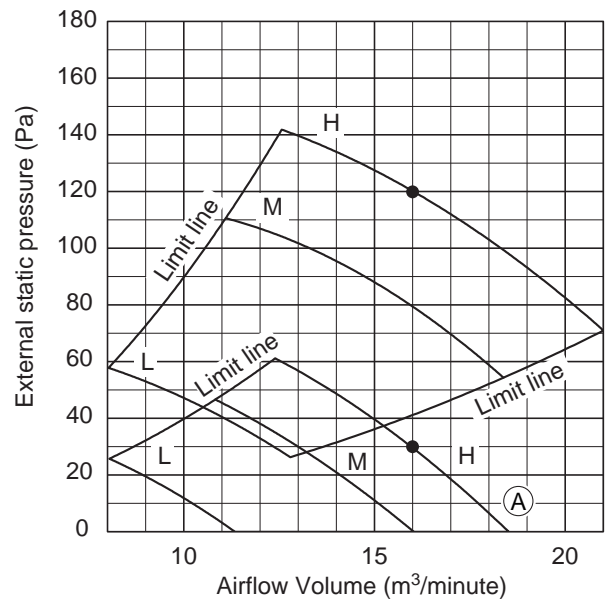

External static pressure 110Pa, 10Pa

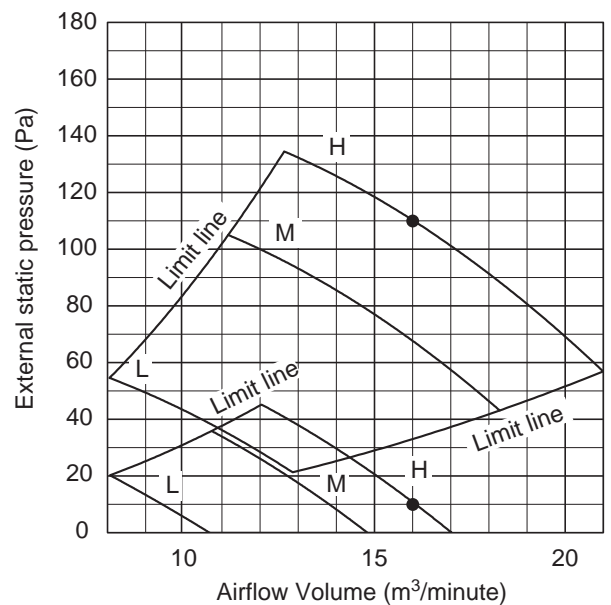

Indoor Units Type 60, 73

Indoor Fan Performance

PQ diagram (Fig. 10-2)

External static pressure 150Pa, 90Pa

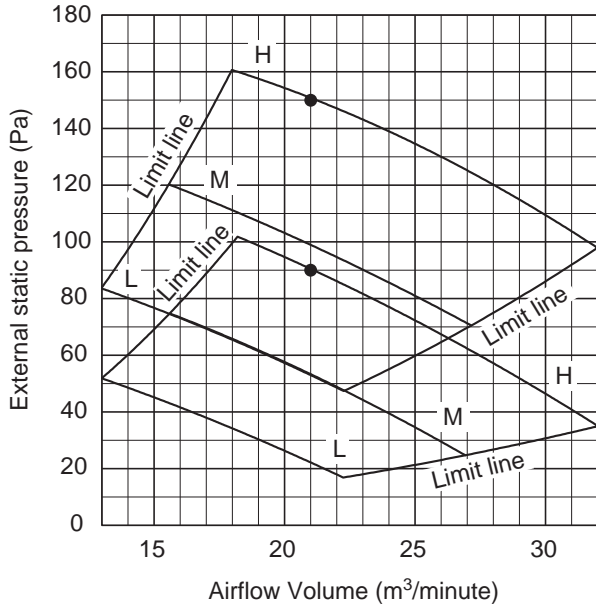

External static pressure 140Pa, 70Pa

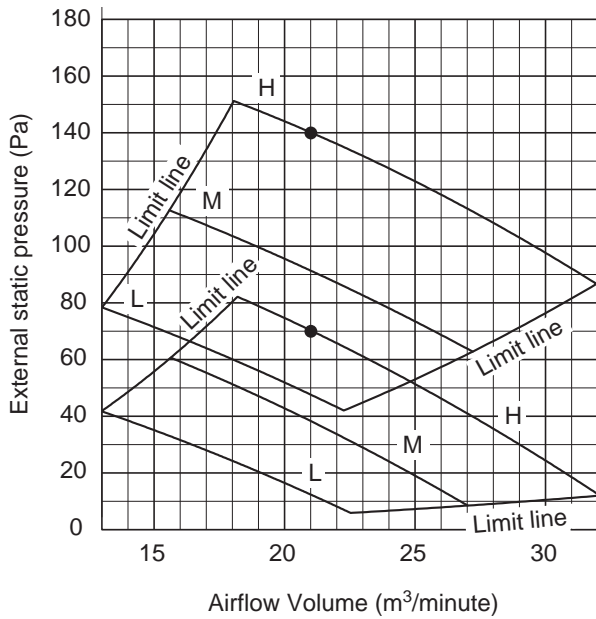

External static pressure 130Pa, 50Pa

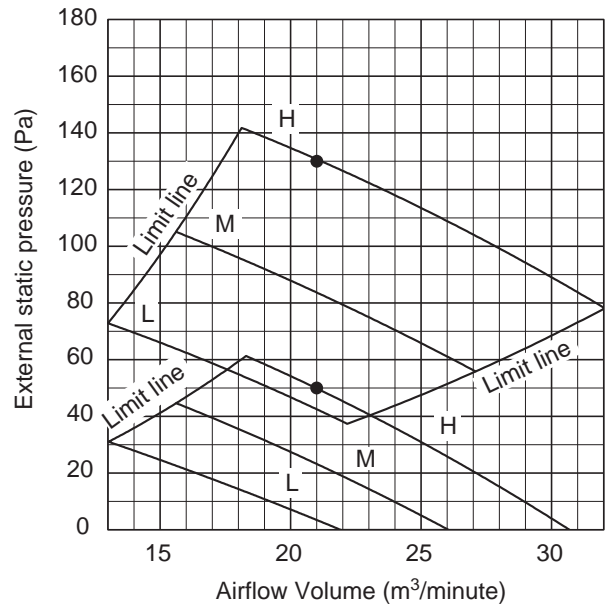

External static pressure 120Pa, 30Pa

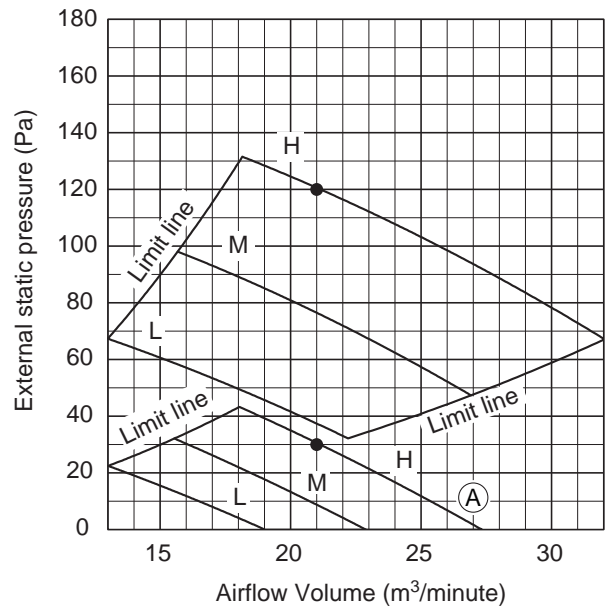

External static pressure 110Pa, 10Pa

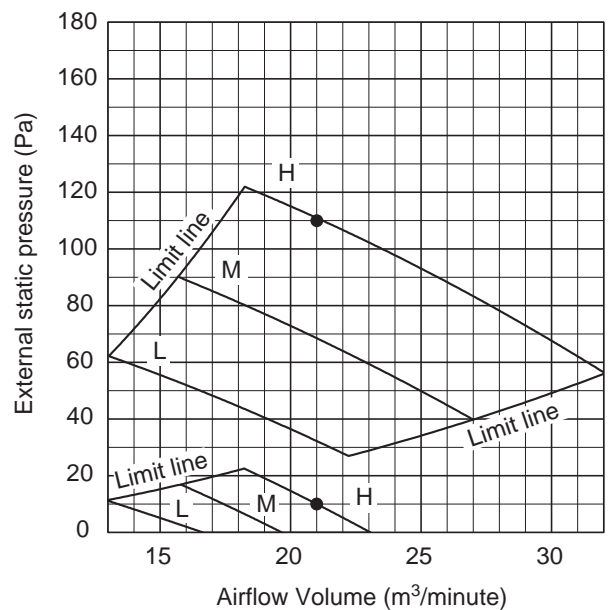

Indoor Units Type 90

Indoor Fan Performance

PQ diagram (Fig. 10-2)

External static pressure 150Pa, 90Pa

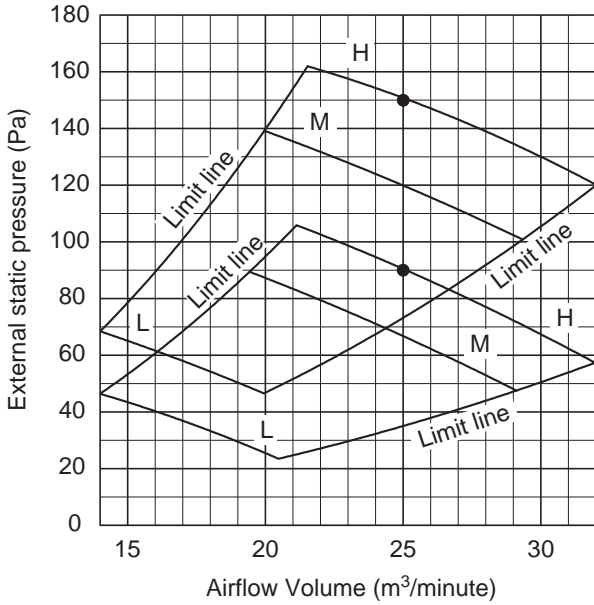

External static pressure 140Pa, 70Pa

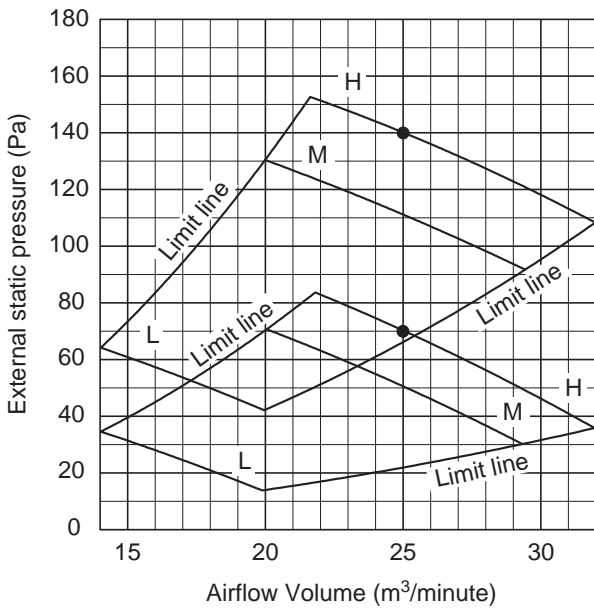

External static pressure 130Pa, 40Pa

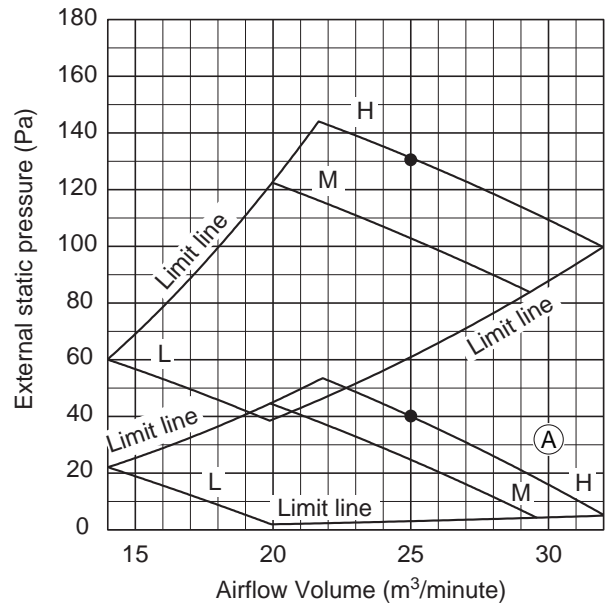

External static pressure 120Pa, 30Pa

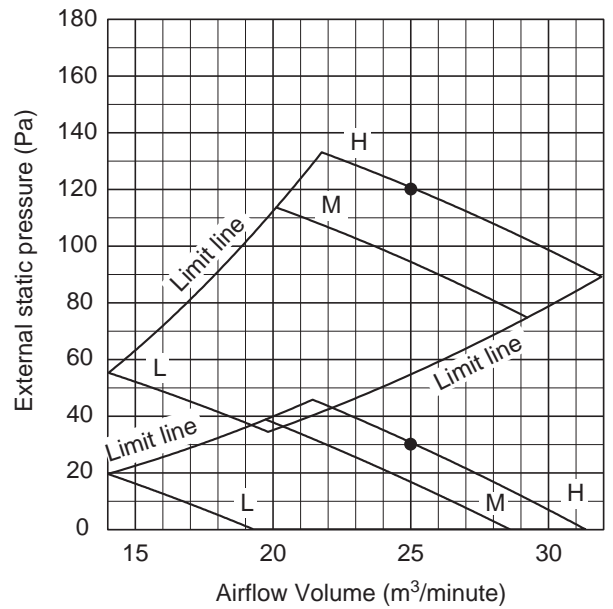

External static pressure 110Pa, 10Pa

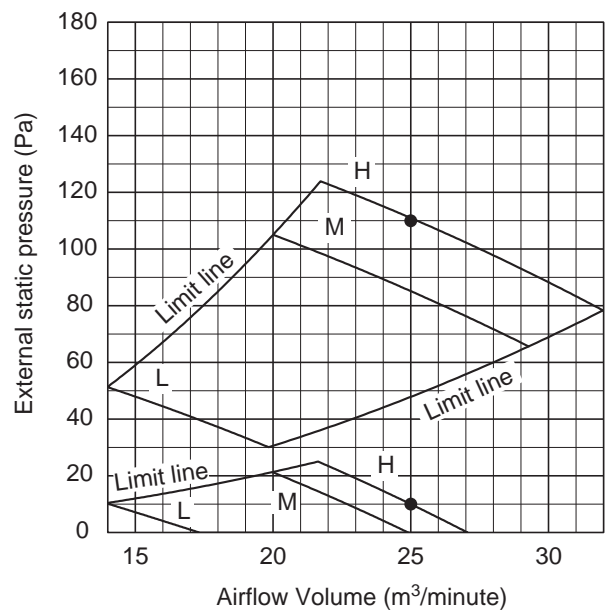

Indoor Units Type 106

Indoor Fan Performance

PQ diagram (Fig. 10-2)

External static pressure 150Pa, 90Pa

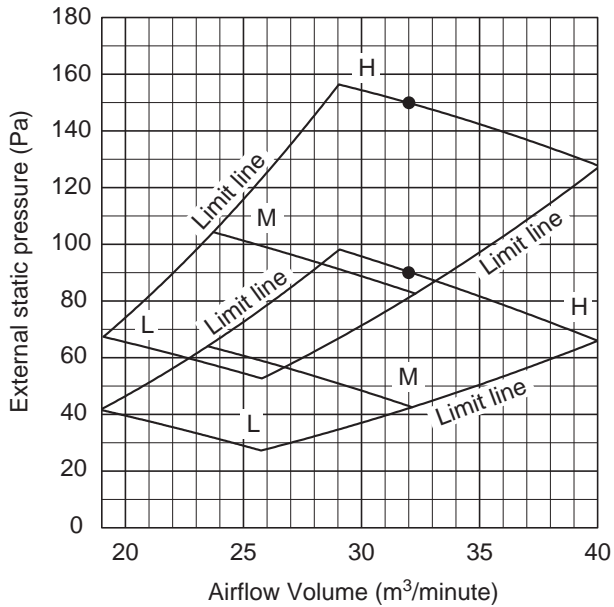

External static pressure 140Pa, 70Pa

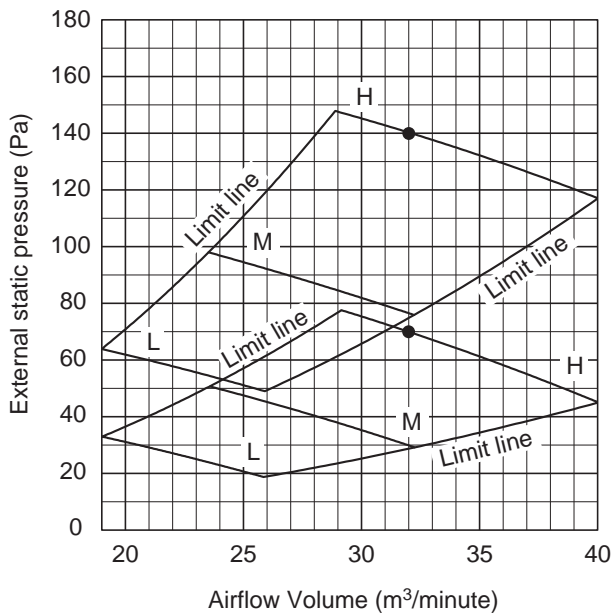

External static pressure 130Pa, 40Pa

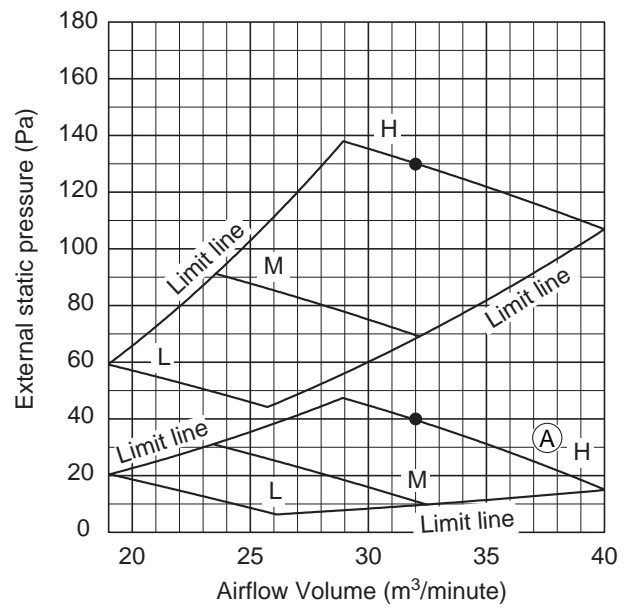

External static pressure 120Pa, 30Pa

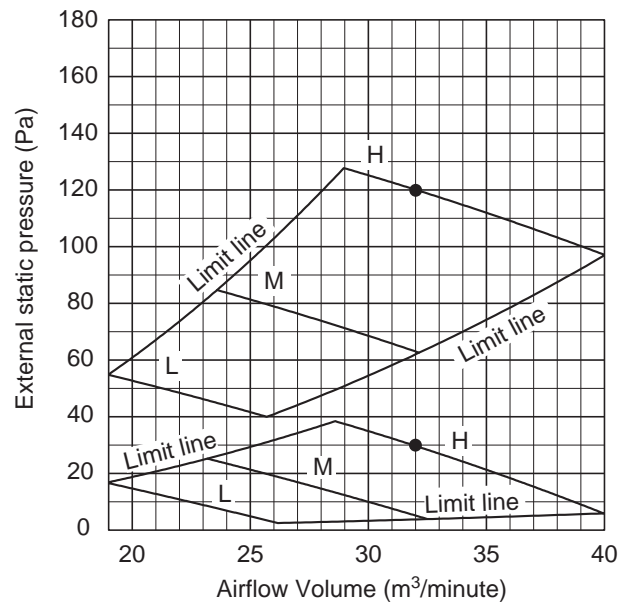

External static pressure 110Pa, 10Pa

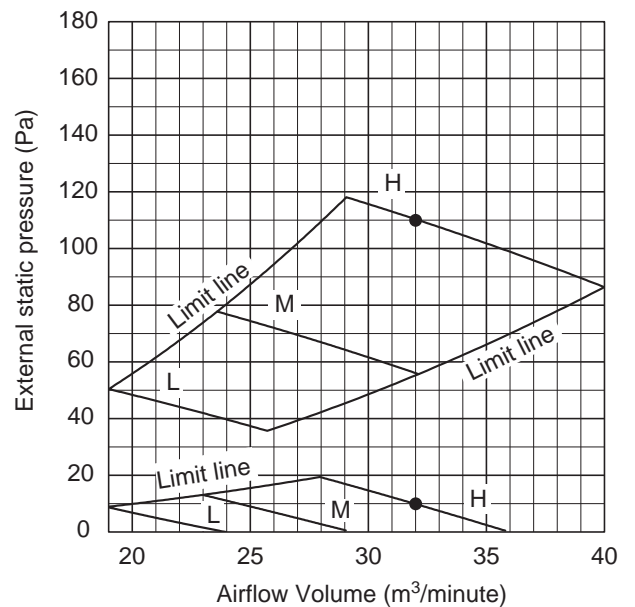

Indoor Units Type 112, 140

Indoor Fan Performance

PQ diagram (Fig. 10-2)

External static pressure 150Pa, 90Pa

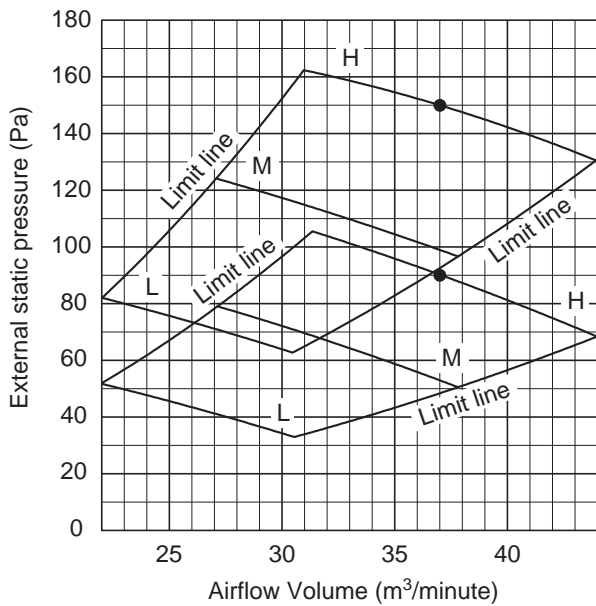

External static pressure 140Pa, 70Pa

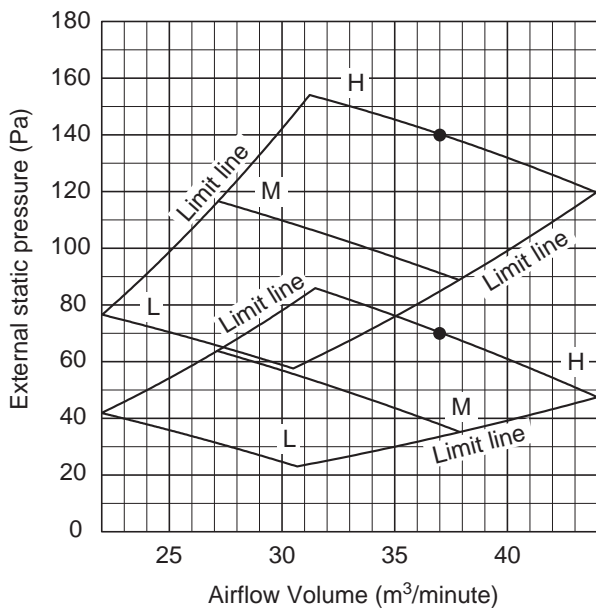

External static pressure 130Pa, 50Pa

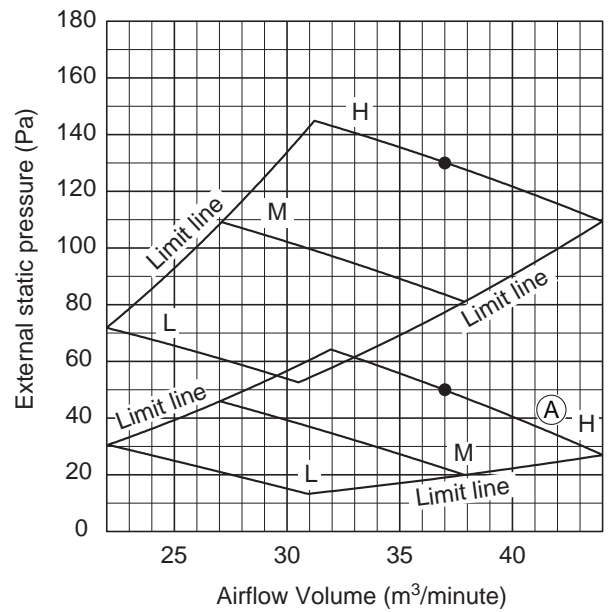

External static pressure 120Pa, 30Pa

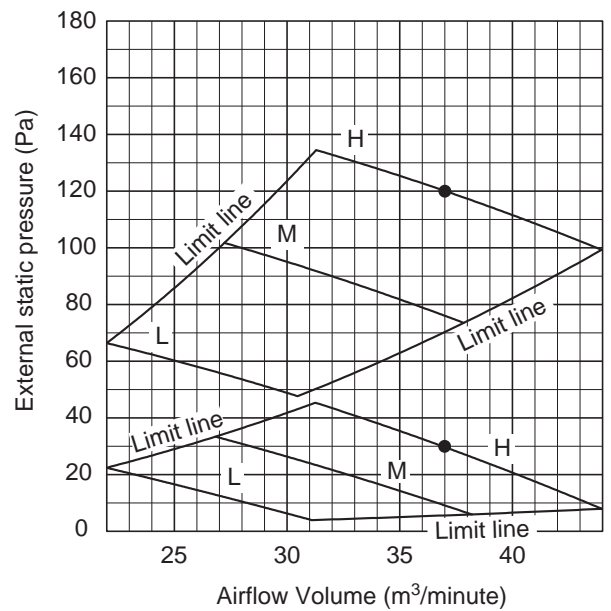

External static pressure 110Pa, 10Pa

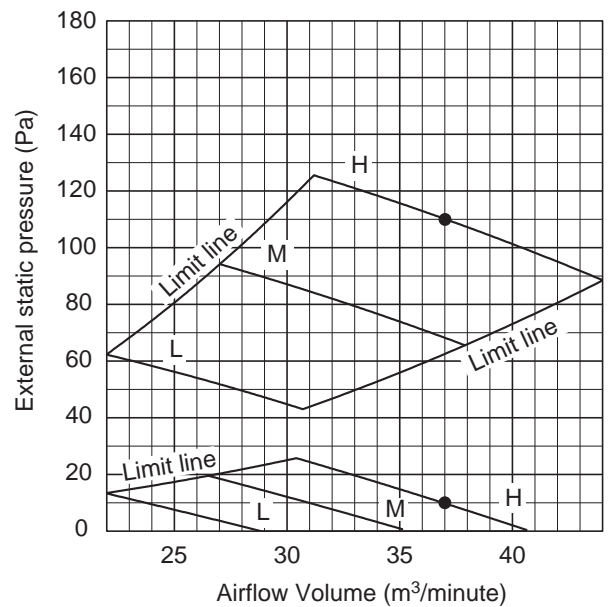

Indoor Units Type 160

Indoor Fan Performance

PQ diagram (Fig. 10-2)

External static pressure 150Pa, 90Pa

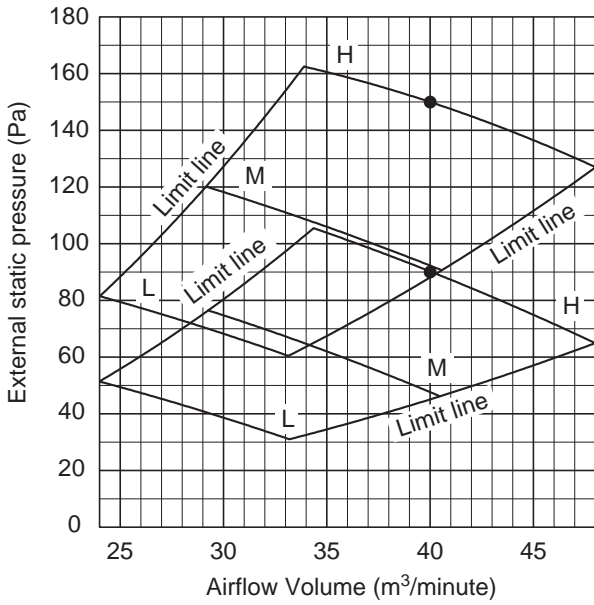

External static pressure 140Pa, 70Pa

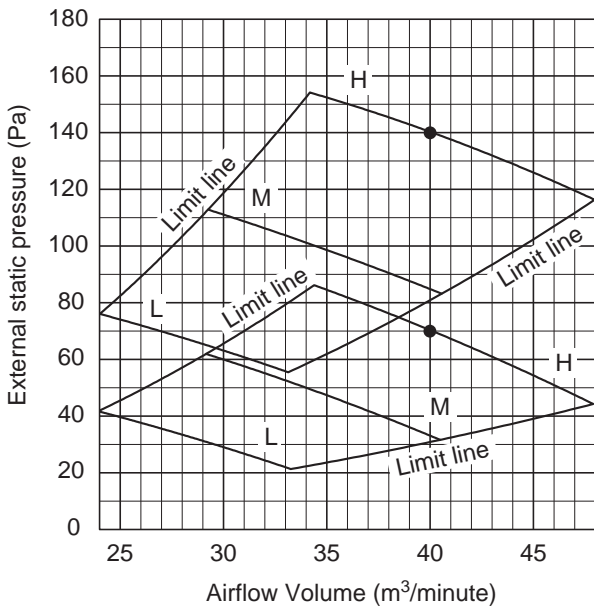

External static pressure 130Pa, 50Pa

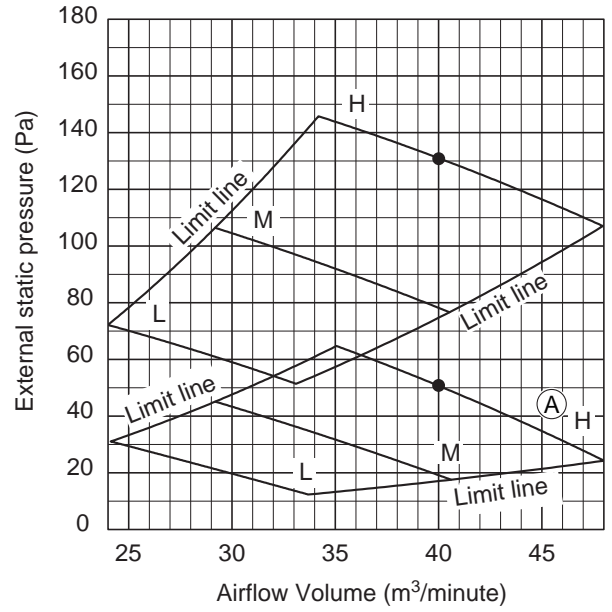

External static pressure 120Pa, 30Pa

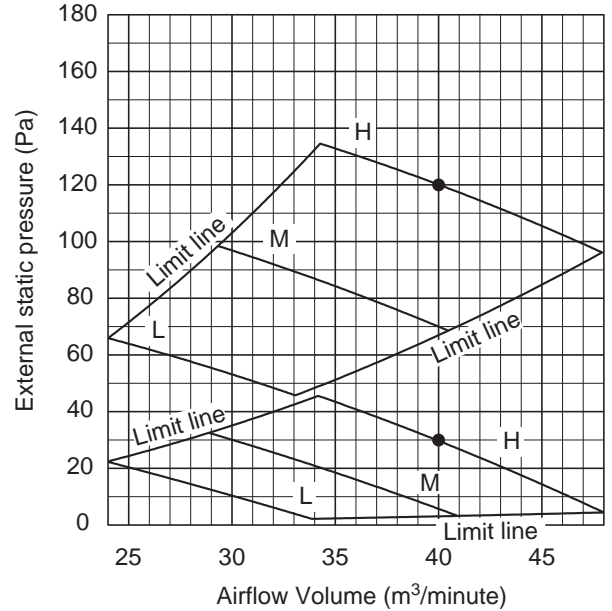

External static pressure 110Pa, 10Pa

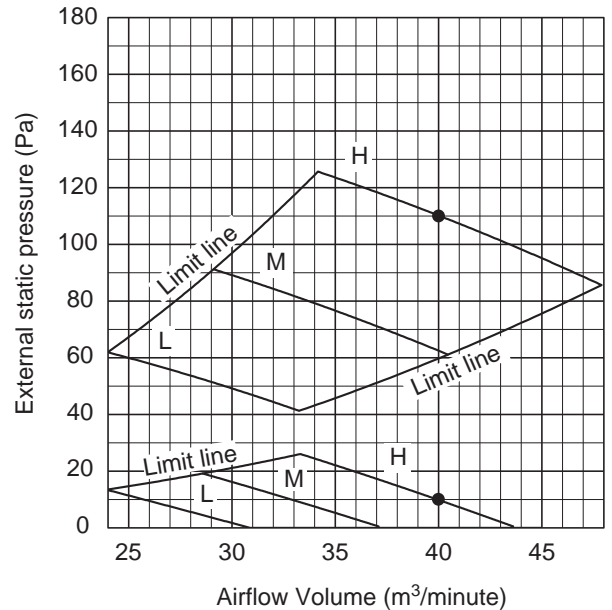

11. APPENDIX

■ Care and Cleaning



WARNING

- For safety, be sure to turn the air conditioner off and also to disconnect the power before cleaning.
- Do not pour water on the indoor unit to clean it. This will damage the internal components (fan motor, etc.) and cause an electric shock hazard.

Air intake and outlet side (Indoor unit)

Clean the air intake and outlet side of the indoor unit with a vacuum cleaner brush, or wipe them with a clean, soft cloth.

If these parts are stained, use a clean cloth moistened with water. When cleaning the air outlet side, be careful not to force the vanes out of place.



CAUTION

- Never use solvents or harsh chemicals when cleaning the indoor unit. Do not wipe plastic parts using very hot water.
- Some metal edges and the fins are sharp and may cause injury if handled improperly; be especially careful when you clean these parts.
- The internal coil and other components of outdoor unit must be cleaned regularly. Consult your dealer or service center.

Air filter

The air filter collects dust and other particles from the air and should be cleaned at regular intervals. If the air conditioner does not cool or warm, the air filter might be clogged. If the filter gets blocked, the efficiency of the air conditioner drops greatly. When cleaning the air filter, consult your dealer or service center.

NOTE

The frequency with which the filter should be cleaned depends on the environment in which the unit is used.

Clean the filter frequently for best performance in the area of dusty or oil spots regardless of filter status.

When maintaining the filter, it may necessary to use a stubby screwdriver.

<How to clean the filter>

Use a vacuum cleaner to remove light dust. If there is sticky dust on the filter, wash the filter in lukewarm, soapy water, rinse it in clean water, and dry it.

<How to remove the filter>

Remove the filter in reverse order under Section “3-2-2. Install the Filter”.

● In case of Installing the Duct (field supply)

Type	F3
Period	(Depends on filter's specifications)

When cleaning the air filter, consult your dealer or service center.

 **CAUTION**

- **Certain metal edges and the condenser fins are sharp and may cause injury if handled improperly; special care should be taken when you clean these parts.**
- **Periodically check the outdoor unit to see if the air outlet or air intake is clogged with dirt or soot.**
- **The internal coil and other components must also be cleaned periodically. Consult your dealer or service center.**

Care: After a prolonged idle period

Check the indoor and outdoor unit air intakes and outlets for blockage; if there is a blockage, remove it.

Care: Before a prolonged idle period

- Operate the fan for half a day to dry out the inside.
- Disconnect the power supply and also turn off the circuit breaker.
- Clean the air filter and replace it in its original position.
- Outdoor unit internal components must be checked and cleaned periodically. Contact your local dealer for this service.

■ Troubleshooting

If your air conditioner does not work properly, first check the following points before requesting service. If it still does not work properly, contact your dealer or a service center.





● Indoor unit

Symptom		Cause
Noise	Sound like streaming water during operation or after operation	<ul style="list-style-type: none"> ● Sound of refrigerant liquid flowing inside unit ● Sound of drainage water through drain pipe
	Cracking noise during operation or when operation stops.	Cracking sound due to temperature changes of parts
Odor	Discharged air is smelled during operation.	Indoor odor components, cigarette odor and cosmetic odor accumulated in the air conditioner and its air is discharged. Unit inside is dusty. Consult your dealer.
Dewdrop	Dewdrop gets accumulated near air discharge during operation	Indoor moisture is cooled by cool wind and accumulated by dewdrop.
Fog	Fog occurs during operation in cooling mode. (Places where large amounts of oil mist exist at restaurants.)	<ul style="list-style-type: none"> ● Cleaning is necessary because unit inside (heat exchanger) is dirty. Consult your dealer as technical engineering is required. ● During defrost operation
Fan is rotating for a while even though operation stops.		<ul style="list-style-type: none"> ● Fan rotating makes operation smoothly. ● Fan may sometimes rotate because of drying heat exchanger due to settings. ● Fan may sometimes rotate in internal cleaning operation mode for a while.
Dust		Dust accumulation inside indoor unit is discharged.
Humming noise comes out.		<ul style="list-style-type: none"> ● This is the sound of nanoe™ X being discharged.
nanoex is not displayed on the remote controller.		<ul style="list-style-type: none"> ● Has nanoe™ X been set to OFF? → Set to ON.
⚠ nanoex is displayed on the remote controller.		<ul style="list-style-type: none"> ● nanoe™ X is considered abnormal. (Contact your dealer.)
Poor cooling or heating performance		<p>The indoor unit is initially designed to control the indoor temperature detected by the built-in room sensor inside the indoor unit. Due to indoor unit installation position, however, the built-in sensor may occasionally sense temperature improperly; for example, temperature difference between the ceiling and floor, lighting apparatus, electric fan, windows or waist-high partition walls, etc.</p> <p>In this case, the unit does not operate properly at the desired temperature.</p> <p>You may change the use of the temperature sensor inside the indoor unit to that of the remote controller.</p> <p>Then the desired room temperature can be controlled properly.</p> <p>For details, consult your dealer.</p>

● Check Before Requiring Services

Symptom	Cause	Remedy
Air conditioner does not run at all although power is turned on.	Power failure or after power failure	Press ON/OFF operation button on remote controller again.
	Operation button is turned off.	<ul style="list-style-type: none"> ● Switch on power if breaker is turned off. ● If breaker has been tripped, consult your dealer without turning it on.
	Fuse blow out.	If blown out, consult your dealer.
Poor cooling or heating performance	Air intake or air discharge port of indoor and outdoor units is clogged with dust or obstacles.	Remove dust or obstruction.
	Fan speed switch is set to "Low".*	Change to "Medium" or "High".*
	Improper temperature settings	See Section "■ Tips for Energy Saving".
	Room is exposed to direct sunlight in cooling mode.	
	Doors and /or windows are open.	
	Air filter is clogged.	See Section "■ Care and Cleaning".
	Too much heat sources in room in cooling mode.	Use minimum heat sources and in a short time.
	Too many people in room in cooling mode.	Reduce temperature settings or change to "Medium" or "High".*

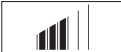
* Fan speed display on the remote controller

High	:		(CZ-RTC4),		(CZ-RTC5B, CZ-RTC6 series)
Medium	:		(CZ-RTC4),		(CZ-RTC5B, CZ-RTC6 series)
Low	:		(CZ-RTC4),		(CZ-RTC5B, CZ-RTC6 series)

If your air conditioner still does not work properly although you checked the points as described above, first stop the operation and turn off the power switch. Then contact your dealer and report the serial number and symptom. Never repair your air conditioner by yourself since it is very dangerous for you to do so. You also report if the inspection mark Δ and the letters E, F, H, J, L, P in combination with the numbers appear on the LCD of the remote controller.

■ Tips for Energy Saving

Avoid

- **Do not block the air intake and outlet of the unit. If either is obstructed, the unit will not work well, and may be damaged.**
- Do not let direct sunlight into the room. Use sunshades, blinds or curtains. If the walls and ceiling of the room are warmed by the sun, it will take longer to cool the room.

Do

- Always try to keep the air filter clean. (See Section “■ Care and Cleaning”.) A clogged filter will impair the performance of the unit.
- To prevent conditioned air from escaping, keep windows, doors and any other openings closed.

NOTE

Should the power fail while the unit is running

If the power supply for this unit is temporarily cut off, the unit will automatically resume operation once power is restored using the same settings before the power was interrupted.

Important Information Regarding The Refrigerant Used

NOTE

Refer to the Installation Instructions attached to the outdoor unit.

